

MakerBot® Replicator® 2X

EXPERIMENTAL 3D PRINTER

— USER MANUAL —

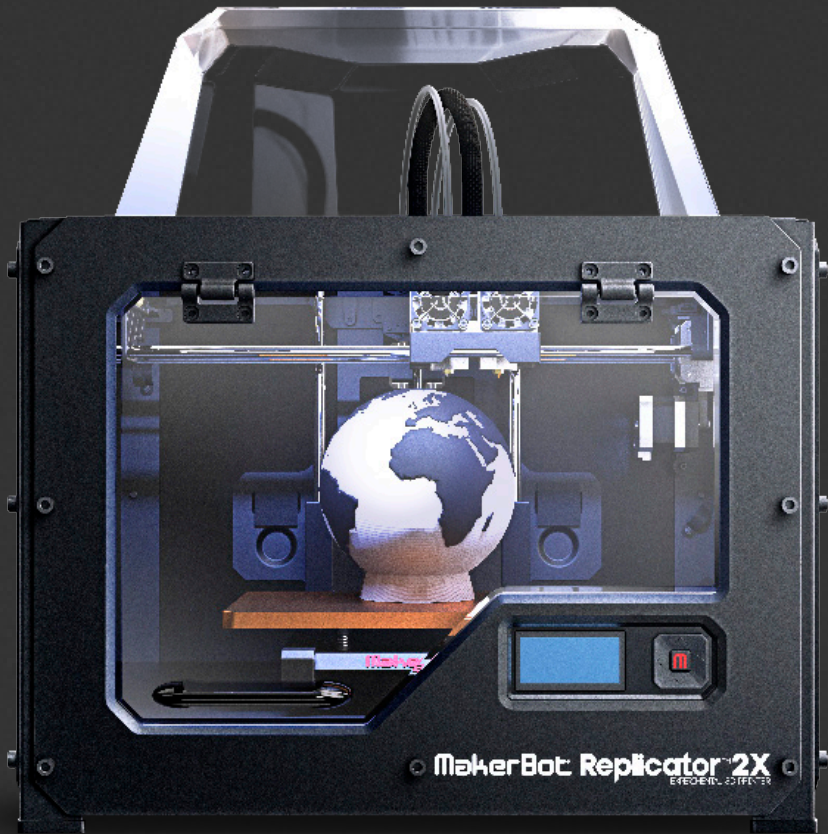



MakerBot®

The product may differ slightly from the images and instructions in this manual as we continue to improve the MakerBot Ecosystem. Please see www.makerbot.com/um_rep_2X for the latest version of the manual.

TABLE OF CONTENTS

1	WELCOME	5
	Legal Notices	6
	Safety and Compliance	8
	Diagrams	10
	How it Works	12
	Accessory Checklist	13
	Filament	14
2	ONBOARD OPERATIONS	16
	The LCD Panel	17
	LCD Menus	18
	Utilities Menu	19
	Info and Settings Menu	21
	Active Build Menu	24
	Leveling the Build Plate	26
	Loading Makerbot Filament	28
3	MAKERBOT DESKTOP	32
	Downloading and Installing MakerBot Desktop	33
	About MakerBot Desktop	35
	The Prepare Screen	36
4	PRINTING WITH YOUR MAKERBOT REPLICATOR 2X	39
	Choosing a Model	40
	Preparing a Model	41
	Printing a Model	45
5	ADVANCED SETTINGS	49
	Quality	50
	Temperature	53
	Speed	54
	Custom Profiles	55
6	MAINTENANCE	56
	Leveling the Build Plate	57
	Replacing Kapton Tape	59
	Lubricating the Z-Axis Rod and Idler Pulley	61
	Realigning the Gantry	63

TABLE OF CONTENTS CONTINUED

	Tightening the X and Y-Axis Pulleys	65
	Filament Care	66
7	 TROUBLESHOOTING	67
	Printing Issues	68
	LCD Error Messages	73
	Misaligned Nozzles	76
	Dos and Don'ts	78
	Useful Tools	79
	Diagnosing Print Quality Issues	80
8	 REFERENCE	85
	Specifications	86
	Glossary	87
	Contact Us	90
	Notes	91



WELCOME

Welcome to the User Manual for the MakerBot Replicator 2X Experimental 3D Printer. Your MakerBot Replicator 2X is optimized for ABS, a traditional thermoplastic that can be tricky and unpredictable. In order to achieve great results, you will need to experiment and tinker. That's why it's so crucial to take the time to learn about your new 3D printer.

In this manual, you will learn how to set up and start using your MakerBot Replicator 2X. You will also be introduced to MakerBot Desktop, software that prepares 3D models for printing and turns them into instructions for your MakerBot Replicator 2X. By the time you finish reading, you will know everything you need to start experimenting.

We are so excited to welcome you to the MakerBot community. Let's get started!

LEGAL NOTICES

PRODUCT WARRANTY

The MakerBot Replicator 2X Experimental 3D Printer is covered by a limited warranty. For terms and conditions, see makerbot.com/legal.

OVERALL PROVISIONS

All information in this user manual is subject to change at any time without notice and is provided for convenience purposes only. MakerBot Industries, LLC and our respective affiliates and suppliers (“MakerBot”) reserves the right to modify or revise this user manual in its sole discretion and at any time and makes no commitment to provide any such changes, updates, enhancements, or other additions to this user manual in a timely manner or at all. You agree to be bound by any modifications and/or revisions. Contact the MakerBot Support Team for up-to-date information.

In order to protect MakerBot proprietary and confidential information and/or trade secrets, this document may describe some aspects of MakerBot technology in generalized terms.

INTELLECTUAL PROPERTY

The design of this user manual and all text, graphics, information, content, and other material are protected by copyright and other laws. The contents are copyright 2009, 2010, 2011, 2012, 2013, 2014 MakerBot. All rights reserved. Certain trademarks, trade names, service marks, and logos (the “Marks”) used in this user manual are registered and unregistered trademarks, trade names, and service marks of MakerBot and its affiliates. Nothing contained in this Manual grants or should be construed as granting, by implication, estoppel, or otherwise, any license or right to use any Marks without the written permission of MakerBot. Any unauthorized use of any information, materials, or Marks may violate copyright laws, trademark laws, laws of privacy and publicity, and/or other laws and regulations.

LEGAL NOTICES

DISCLAIMERS

MakerBot does not warrant the accuracy or completeness of the information, products, or services provided by or through this user manual and assumes no responsibility for any typographical, technical, or other inaccuracies in this user manual, which is provided “as is” and without any express or implied warranties of any kind, including warranties of merchantability, fitness for a particular purpose, or non-infringement of intellectual property. MakerBot makes no warranties to those defined as “consumer” in the Magnuson-Moss Warranty-Federal Trade Commission Improvement Act. In connection with your use of this user manual, MakerBot shall not be liable to you for any damages whatsoever, be they direct, economic, commercial, special, consequential, incidental, exemplary, or indirect damages, even if MakerBot has been advised of the possibility of such damages, including without limitation, loss of business revenue or earnings, lost data, or lost profits. MakerBot assumes no responsibility, nor will be liable, for any damages to, or any viruses or malware that may infect, your computer, telecommunication equipment, or other property caused by or arising from your downloading of any information or materials related to this user manual. The foregoing exclusions do not apply to the extent prohibited by law; please refer to your local laws for any such prohibitions.

SAFETY AND COMPLIANCE

RADIO AND TELEVISION INTERFERENCE

This equipment has been tested and found to comply with the limits for a Class B digital device, pursuant to Part 15 of the FCC rules. These limits are designed to provide reasonable protection against harmful interference in a residential installation. This equipment generates, uses and can radiate radio frequency energy and, if not installed and used in accordance with the instructions, may cause harmful interference to radio communications. However, there is no guarantee that interference will not occur in a particular installation. If this equipment does cause harmful interference to radio or television reception, which can be determined by turning the equipment off and on, the user is encouraged to try to correct the interference by one or more of the following measures:

- Reorient or relocate the receiving antenna.
- Increase the separation between the equipment and the receiver.
- Connect the equipment into an outlet on a circuit different from that to which the receiver is connected.
- Consult the dealer or an experienced radio/TV technician for help.

You may also find helpful the following booklet, prepared by the FCC: "How to Identify and Resolve Radio-TV Interference Problems." This booklet is available from the U.S. Government Printing Office, Washington D.C. 20402.

Changes and Modifications not expressly approved by the manufacturer or registrant of this equipment can void your authority to operate this equipment under Federal Communications Commission rules.

MANUFACTURER
MakerBot Industries, LLC
One MetroTech Center, 21st Floor
Brooklyn, NY 11201
347.334.6800



SAFETY AND COMPLIANCE CONTINUED



Safety alert symbols precede each safety message in this manual.

These symbols indicate potential safety hazards that could harm you or others or cause product or property damage.



WARNING: The MakerBot Replicator 2X Experimental 3D Printer generates high temperatures. Always allow the MakerBot Replicator 2X to cool down before reaching inside.



WARNING: The MakerBot Replicator 2X includes moving parts that can cause injury. Never reach inside the MakerBot Replicator 2X while it is in operation.



WARNING: Do not leave the MakerBot Replicator 2X unattended during operation.



CAUTION: Use caution when printing with materials that have not been approved by MakerBot for use with the MakerBot Replicator 2X.



CAUTION: In case of emergency disconnect power supply from wall socket.



CAUTION: The socket outlet must be located near the equipment and must be easily accessible



CAUTION: The MakerBot Replicator 2X melts plastic during printing. Plastic odors are emitted during this operation. Make sure to set up the MakerBot Replicator 2X in a well-ventilated area.

MAKERBOT REPLICATOR 2X DIAGRAMS

1 Gantry System

2 LCD Panel

3 Heated Build Plate

4 Build Platform

5 Threaded Z-Axis Rod

6 Enclosure Door Handle

7 Filament Guide Tubes

8 Extruder Cable

9 Extruders

10 Filament Spool

11 Spool Holders

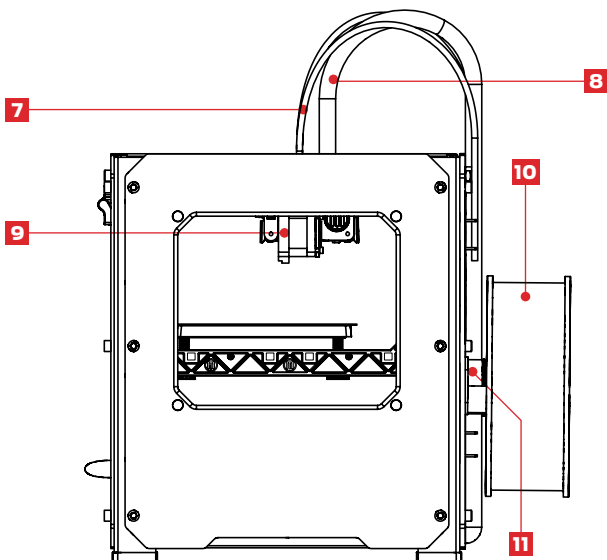
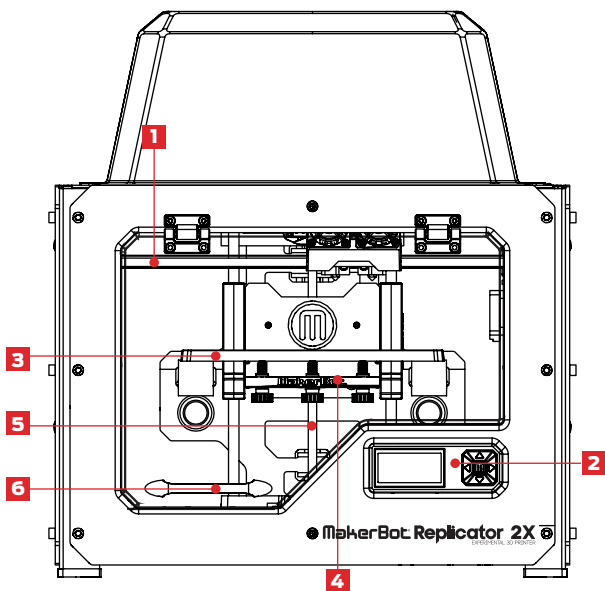

MAKERBOT REPLICATOR 2X DIAGRAMS CONTINUED

1 Fan Guards

2 Extruder Fans

3 Extruder Nozzles

4 Fan Bolts

5 Cartridge Heaters

6 Thermal Cores

7 Drive Blocks

8 Extruder Cable Mount

9 Motor Cable Connectors

10 Extruder Motors

11 Heat Sinks

12 Bar Mount

13 Spacers

14 Extruder Carriage

15 Extruder Arms

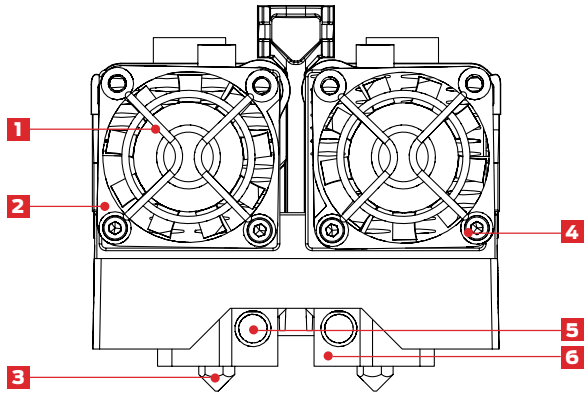

Front view of extruders

11 Heat Sinks

12 Bar Mount

13 Spacers

14 Extruder Carriage

15 Extruder Arms

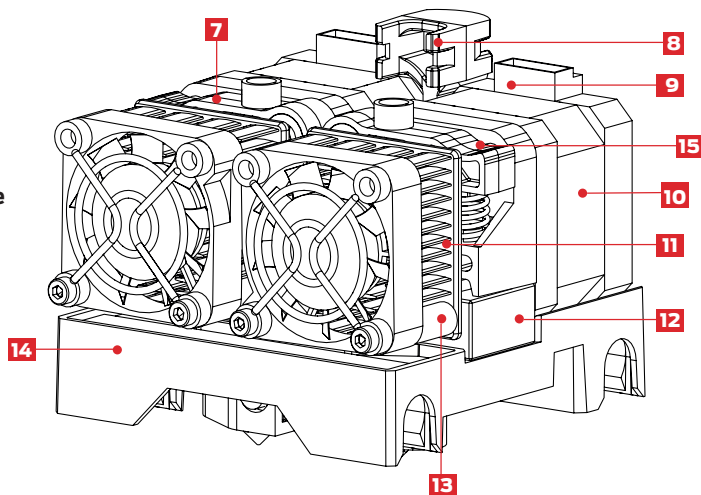

Angled view of extruders

HOW IT WORKS

The MakerBot Replicator 2X Experimental 3D Printer makes solid, three-dimensional objects out of melted MakerBot ABS Filament. First, use MakerBot Desktop Software to translate 3D design files into instructions for the MakerBot Replicator 2X. Then transfer those instructions to the MakerBot Replicator 2X via USB cable or SD card. The MakerBot Replicator 2X will melt the filament and squeeze it out onto the build plate in thin lines to build your object layer by layer. This method is called fused deposition modeling.

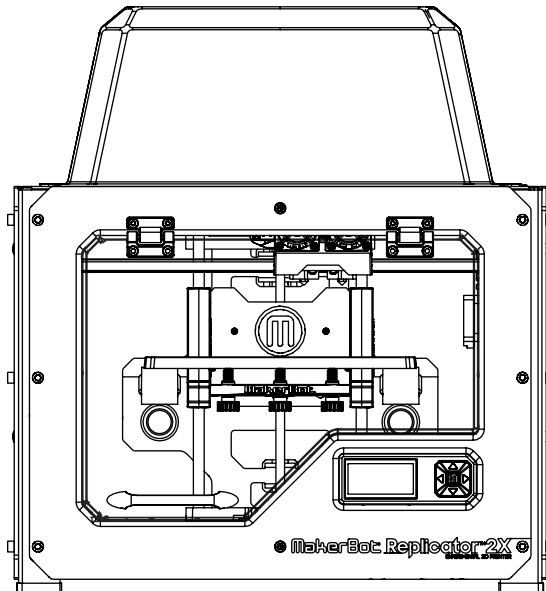

ACCESSORY CHECKLIST

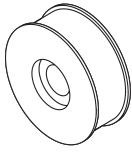

1

MakerBot ABS Filament [1 lb Spool]

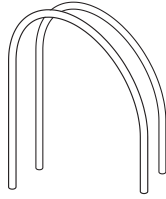

2

Filament guide tubes

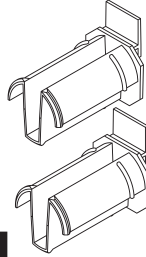

2

Spool holders

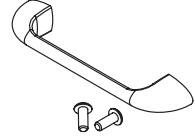

1

Handle and bolts

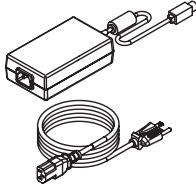

1

Power supply and cable



1

USB-A to USB-B cable

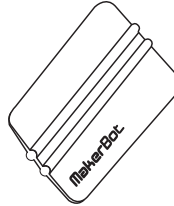

1

MakerBot tape applicator

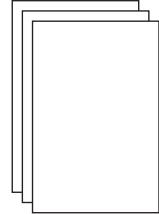

3

Kapton tape sheets

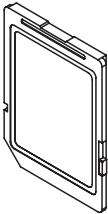

1

SD card

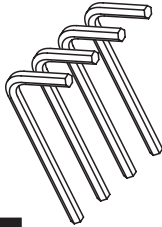

4

Hex wrenches



1

PTFE-based grease

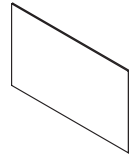

1

Support card



More options available at store.makerbot.com/abs-filament

FILAMENT

Your MakerBot Replicator 2X Experimental 3D Printer is optimized to print objects using ABS plastic filament, 1.75 mm in diameter. The Makerbot Replicator 2X can also use 1.75 mm filament made from other plastics with similar properties. Similar filament, known as plastic welding rod, is used in a number of other applications, but filament made for 3D printing needs to be more consistent in diameter than ordinary plastic welding rod.

Sometimes 1.75 mm plastic filament can vary in size between 1.65 mm and 1.85 mm. The extruders in the MakerBot Replicator 2X can accommodate this range of sizes. The consistency of the filament diameter is more important than the size of the diameter. Filament that is thicker in some places than in others is difficult for the extruder to grip. It can also result in poor print quality: a section of plastic that is too thin will result in a section of your print that does not contain enough plastic and a section of filament that is too thick will result in a section of your print that contains too much.

If you load a new roll of filament that is slightly thicker or thinner than your previous roll, the extruders might feed too much or too little plastic for your print. To fix this problem, adjust the feedstock diameter in the MakerBot Slicer through MakerBot Desktop's custom profiles feature. For more on custom profiles and the feedstock diameter setting, see the Using Custom Slicing Profiles guide online at:

www.makerbot.com/support/new/Desktop

Be careful with your filament. Keep it dry; humidity might cause it to expand. Avoid letting the filament loosen on the roll; this can result in tangles which could cause your filament to break or get stuck during a print.

ABOUT ABS

ABS is short for Acrylonitrile Butadiene Styrene. It is made of a combination of those three plastics. The three plastics can be mixed in different proportions to formulate ABS intended for different uses.

ABS is tough and somewhat flexible. It becomes softer with increased temperatures, but at the extrusion temperatures used in a MakerBot Replicator 2X it remains fairly viscous. That means that ABS melts quickly inside the extruder but doesn't drip during travel moves. ABS can also withstand heat well enough that we use it to make the plastic components of the extruders of your MakerBot Replicator 2X.

Your MakerBot Replicator 2X can also print with MakerBot Dissolvable Filament, a material that easily dissolves in a limonene bath. If you're printing a model with a raft and/or supports, MakerBot Dissolvable Filament is a great option for printing those elements. Simply assign one extruder to the ABS filament that will print your model, and assign the other extruder to the dissolvable filament that will print any part you want to remove. Read more about dual extrusion in Chapter 4.

2

ONBOARD OPERATIONS

The MakerBot Replicator 2X Experimental 3D Printer has an onboard LCD panel through which you can initiate a number of processes, such as leveling the build plate or loading filament. You can also use the LCD panel to choose settings such as LED color or view information like your printer's statistics. This chapter describes all menus and options available on the LCD panel, and goes into detail on leveling the build plate and loading and unloading filament.

THE LCD PANEL

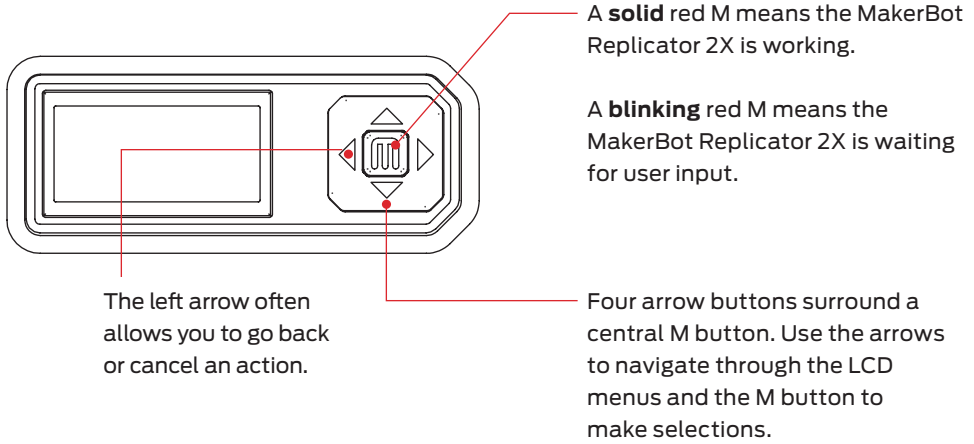

THE STARTUP SCRIPT

The first time you turn on your MakerBot Replicator 2X, the printer will run a startup script on the LCD panel. Follow those instructions to level the build plate, load filament, and print a test print. If you don't see the startup script, use the up and down arrow buttons to scroll through the top-level menu on the LCD panel, and use the M button to select Utilities. Then scroll to Run Startup Script and select it. You can use these menus to return to the Startup Script at any time. You can also view videos of the startup process on the MakerBot Replicator 2X at mbot.co/1qfJkOja. If you have any problems or questions, refer to the Troubleshooting and Maintenance chapters, or visit www.makerbot.com/support/new/MakerBot_Replicator_2X.

LCD MENUS

The following is a list of all options and settings available through the LCD panel on your MakerBot Replicator 2X.

TOP LEVEL ENTRIES

Before you have selected anything in the LCD panel, you will see these top-level menu entries:

Build from SD

This option allows you to print an X3G file from an SD card.

- Use the M button to select **Build from SD**.
- Use the up and down arrow buttons to choose from the list of files on your SD card.
- Press M to start a print.
- Select **Exit Menu** or press the left arrow button to return to the top-level menu.

Preheat

To preheat your MakerBot Replicator 2X, select **Preheat**. Preheating reduces the amount of time it takes to heat the plate and extruders when you begin a print.

- Choose the parts of the MakerBot Replicator 2X that you want to preheat. Use the arrow buttons to navigate to “Right Tool,” “Left Tool,” or “Platform.” Press the “M” button to toggle a setting between “ON” and “OFF.” For example, if you want to print with dual extrusion, set both extruders to ON. If you are printing with ABS, set the platform to ON.
- To start the preheat, use the arrow buttons to navigate to “Start Preheat!”

then press the M button.

- To stop the preheating process, return to the Preheat menu and select “Cool!”

NOTE: You will need to go to **Preheat Settings** to set the temperatures that will be used in this Preheat function. See [page 23](#) for more on **Preheat Settings**.

Utilities

The **Utilities** menu contains controls for your MakerBot Replicator 2X and scripts for processes like loading filament and leveling the build plate. More information on each setting in the Utilities menu is available on page 19.

Info and Settings

The **Info and Settings** menu displays information about your MakerBot Replicator 2X and allows you to change settings on your MakerBot Replicator 2X. More information on each setting in the Info and Settings menu is available on page 21.

UTILITIES MENU

The **Utilities** menu contains controls for your MakerBot Replicator 2X and scripts for processes like loading filament and leveling the build plate.

Monitor Mode. This entry displays the current temperature of your extruders and build plate. The display is updated as the temperatures change.



Change Filament. This entry launches scripts that walk you through loading and unloading filament. See **Help Text** in the **General Settings** section below for information on how to make the scripts less verbose.

To cancel any of the **Change Filament** scripts, press the left arrow button and select “Yes” when prompted.

See page 28 for detailed instructions on how to Change Filament.

Level Build Plate. This entry walks you through the process for leveling the build plate. The script moves the extruders to different points on the plate and prompts you to adjust the plate height at each point.

To cancel the **Level Build Plate** script, press the left arrow button and select “Yes” when prompted.

See page 26 for detailed instructions on how to level the build plate.

Home Axes. This entry moves your build platform and extruders to their default positions.

Jog Mode. This entry allows you to change the position of the build platform and the extruders. Use the left and right arrow buttons to select the X, Y, or Z-axis, the up and down arrow buttons to move your extruders or build platform along the chosen axis, and the M button to exit Jog Mode. Jogging the Z-axis will move your platform up and down, and jogging the X and Y-axes will move your extruder right and left and backwards and forwards, respectively.

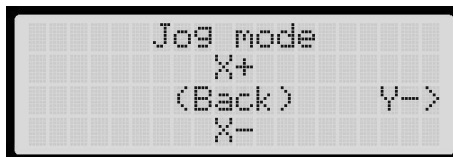

UTILITIES MENU CONTINUED

Run Startup Script. This entry launches the startup script. The Startup Script runs automatically the first time you power on the MakerBot Replicator 2X. The Startup Script walks you through the steps for leveling your build plate, loading filament into the right extruder, and printing from the SD card. To exit the Startup Script, press the left arrow button. You will not be able to exit the Startup Script until the leveling portion of the script begins.

Disable Steppers/Enable Steppers. This entry allows you to toggle on and off the stepper motors that move the extruders and build platform. If you need to manually move the build platform or the extruders, you must first disable the stepper motors.

Blink LEDs/Stop Blinking. This entry allows you to toggle on and off blinking. When toggled on, the LEDs in the MakerBot Replicator 2X will start blinking. When toggled off, the LEDs in the MakerBot Replicator 2X will stop blinking.

Calibrate Nozzles. This entry launches a script that allows the MakerBot Replicator 2X to correctly locate the two extruder nozzles. Use this script if your dual extrusion prints don't appear to line up correctly on the plate. The script will print a series of lines with each nozzle and ask you to choose the ones that line up best. Your MakerBot Replicator 2X will store that information and use it to make your dual extrusion prints align better in the future.

Exit Menu. This entry returns you to the top-level menu.

THE INFO AND SETTINGS MENU

The **Info and Settings Menu** displays information about your MakerBot Replicator 2X and allows you to change settings on your MakerBot Replicator 2X.



```
>Bot Statistics
General Settings
Preheat Settings
Version Number
```

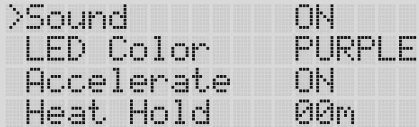

```
>Sound          ON
LED Color      PURPLE
Accelerate     ON
Heat Hold      00m
```

Bot Statistics. This entry displays the total build time, in hours and minutes, during the lifetime of your MakerBot Replicator 2X. It also displays the duration of the last completed build.

General Settings. This entry leads to a sub-menu that allows you to change settings on your MakerBot Replicator 2X. To navigate the entries under

General Settings:

- Use the up and down arrow buttons to navigate to the setting you want to change.
- Press the M button to select the setting you want to change.
- Use the up and down arrow buttons to scroll through the available options for each setting.
- Press the M button to select and confirm your change to a setting.

THE INFO AND SETTINGS MENU CONTINUED

GENERAL SETTINGS CONTINUED

Sound. This entry toggles the indicator sounds ON and OFF. Setting this entry to OFF stops the MakerBot Replicator 2X from beeping when you turn it on or when a print finishes. However, this option will not eliminate all sound made by your MakerBot Replicator 2X. The sounds you hear during printing come from the stepper motors and cannot be turned off.

LED Color. This entry allows you to change the color of the LEDs in the frame of the MakerBot Replicator 2X. The LEDs can be set to WHITE, RED, ORANGE, PINK, GREEN, BLUE or PURPLE, or turned OFF.

Accelerate. This entry toggles acceleration ON and OFF. Acceleration is set to ON by default. Acceleration allows your MakerBot Replicator 2X to operate more smoothly. If you set Acceleration to OFF, do not use printing speeds faster than 45mm/s.

Heat Hold. This entry tells your MakerBot Replicator 2X to continue heating your extruders after a build is cancelled. You can set the hold time from one minute to thirty minutes. To turn this setting off, set it to zero minutes.

Help Text. This entry toggles verbose help text ON and OFF. Turning it ON provides verbose help text during the leveling filament and loading/unloading filament scripts. Turning it OFF provides abbreviated help text during scripts.

Heat LEDs. This entry toggles heat indicators ON and OFF. When this entry is set to ON, the LED color will change from the default color to blue when the heating process begins and from blue to red when the extruders start to heat. When the MakerBot Replicator 2X reaches the target temperatures, the LED color returns to the default color.

Tool Count. This entry displays the number of extruders your MakerBot has. The MakerBot Replicator 2X has dual extruders.

Heated Plate. This entry displays whether your MakerBot has a heated build plate. The MakerBot Replicator 2X has a heated build plate.

Exit menu. This entry returns you to the Info and Settings menu.

THE INFO AND SETTINGS MENU CONTINUED

Preheat Settings. This entry lets you change the preheat temperatures for the extruders and build plate. Remember that the temperatures are in degrees Celsius.

- Use the up and down arrow buttons to navigate to the setting you want to change (Right Tool, Left Tool, Platform)
- Press the M button to select the setting you want to change.
- Use the up and down arrow buttons to scroll through the available options for each setting.
- Press the M button to select and confirm your setting.

Version Number. This entry displays the version number for the firmware on your MakerBot Replicator 2X.

Restore Defaults. This entry restores your MakerBot Replicator 2X to the default, factory settings. This option affects only settings that you can change through the LCD menus. Settings that you can change only using MakerBot Desktop will not be restored to their defaults.

Exit menu. This entry returns you to the top-level menu.

ACTIVE BUILD MENU

The LCD panel includes options and settings for use during printing. To access these settings during a print, press the left arrow button.



Pause/Unpause. This entry allows you to stop a print briefly. During Pause, your extruders and build platform will not move from their current locations. Use Pause only to stop a print briefly. MakerBot does not recommend allowing a heated nozzle to remain stationary and in contact with your print for a long period of time. During a pause, the menu option will change to **Unpause**. Press M to resume printing.

Cancel Build. This entry stops a build permanently. After you choose this option, you will be prompted to confirm that you want to cancel the build.

Change Filament. This entry allows you to move the extruders away from your print, change filament, and then resume the print. This entry is useful for printing multi-colored objects or for changing an empty spool of filament. After you change the filament, press the left arrow button to return to the **Active Build Menu**. Then select the entry for **Resume Build**.

Sleep (Cold Pause)/Resume Build.

This entry allows you to pause a print for long periods of time. When you select this option, your MakerBot Replicator 2X will complete any queued commands before moving the extruder away from your print and allowing the extruders and build plate to cool. During a cold pause, the menu option will change to **Resume Build**. Press M to resume printing.

Z Pause Height. This entry allows you to set a height at which your Replicator 2X will pause. When you select this option, you will see two additional settings: **Z Position** and **Pause Active**. To set the pause height, scroll to Z Position, press the M button, and use the arrows to increase the pause height in millimeters. Press the M again to confirm the height. Scroll to **Pause Active** and use the M button to toggle the setting ON and OFF. When **Pause Active** is set to ON, a Z height pause will be triggered, even if the Z Position is set to 0.

Filament Fan. This entry allows you to set an active cooling fan to ON or OFF during a build. The MakerBot Replicator 2X does not include an active cooling fan.

ACTIVE BUILD MENU CONTINUED

LED Color. This entry allows you to change the color of the LEDs in the frame of the MakerBot Replicator 2X. The LEDs can be set to WHITE, RED, ORANGE, PINK, GREEN, BLUE or PURPLE, or turned OFF. Use the up and down arrow buttons to scroll through the available colors. Press the M button to select and confirm your selection.

Build Statistics. This entry displays the elapsed time for the current build and the line number of the command being executed by your Replicator 2X.

Back to Monitor. This entry returns you to the Monitor screen. The Monitor screen alternates between displaying the percentage of the print that has been completed and elapsed print time. The Monitor screen also displays the temperatures of both extruders and the build plate.

LEVELING THE BUILD PLATE

LEVELING THE BUILD PLATE

To run the leveling script, use the LCD panel to navigate to **Utilities > Level Build Plate**.

WHY LEVELING IS IMPORTANT

- If the build plate is too far from the extruder nozzles, or if one part of the plate is farther away from the nozzles than another part, your 3D prints might not stick to the build plate.
- If the build plate is too close to the extruder nozzles, the build plate can block the MakerBot Filament from extruding from the nozzles. This can also tear the Kapton tape applied to the build plate and scratch the aluminum surface underneath.
- Leveling your build plate will help ensure that objects adhere well to the plate.

HOW TO LEVEL THE BUILD PLATE

Three knobs lower and raise the build plate.

- Tightening the knobs [turning them counterclockwise] moves the build plate away from the extruder nozzles.
- Loosening the knobs [turning them clockwise] moves the build plate closer to the extruder nozzles.

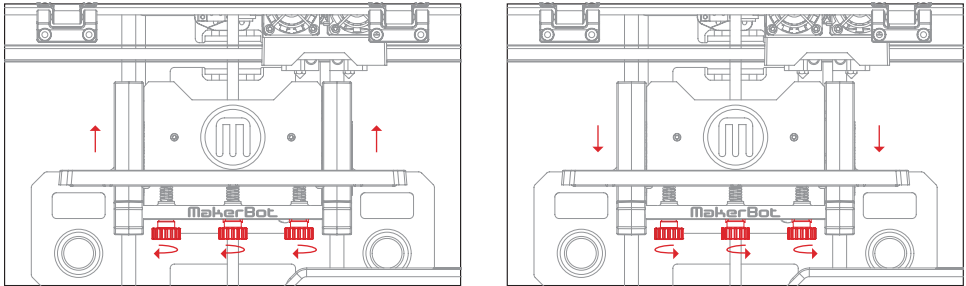

The distance between the extruder nozzles and the build plate should be about the thickness of the MakerBot Support card included with your MakerBot Replicator 2X.

NOTE: To view a video of the build plate leveling process, visit mbot.co/1DIJBX.

LEVELING THE BUILD PLATE CONTINUED

```
Tighten each of the
three knobs under
the build platform
about four turns.
```

1. Adjust the Knobs

When directed by the LCD screen, tighten each of the three knobs underneath the build platform approximately four turns. Next, the script will prompt you to adjust the knobs individually. Use the MakerBot Support business card or a thin piece of paper to check the plate height above each knob.

As you adjust each knob, make sure the MakerBot Support card just slides between the nozzles and build plate. You should feel some friction on the card but still be able to easily pass the card between the plate and the extruder nozzles without tearing or damaging the card.

```
Adjust the rear
knob until paper
just slides between
nozzle and plate
```

2. Adjust Each Knob Again

The script will prompt you to adjust each knob again. This allows for fine tuning. This time, the Support card should slide between the build plate and nozzles with more friction.

```
Now let's triple
check-- paper should
just slide between
nozzle and plate
```

3. Confirm Your Adjustment

After the second set of adjustments, the nozzles will move to the center of the build plate. Confirm that the MakerBot Support card slides between the nozzles and plate with a moderate amount of friction.

NOTE: During leveling, it is okay for the nozzle to be very slightly closer to the center of the build plate than to the rest of the plate.

LOADING MAKERBOT FILAMENT

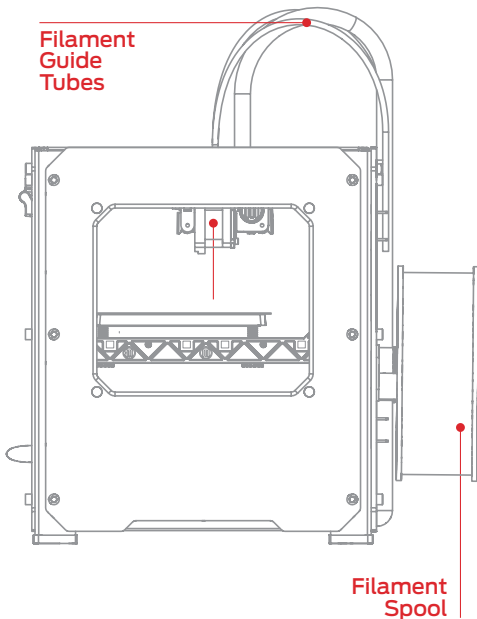

1. Remove the Enclosure Lid

Lift the enclosure lid from the top of the MakerBot Replicator 2X and set it aside.

2. Detach the Filament Guide Tube

Locate where the filament guide tube enters the extruder. Detach the guide tube by gently pulling it out of the extruder.

3. Feed the Filament through the Filament Guide Tube

Free the end of the MakerBot ABS Filament from your spool. Use scissors to cut away any bent filament and feed the end of the spooled filament into the filament guide tube where it attaches to the back of the MakerBot Replicator 2X. Continue to feed the filament in until it emerges from the other end of the tube.

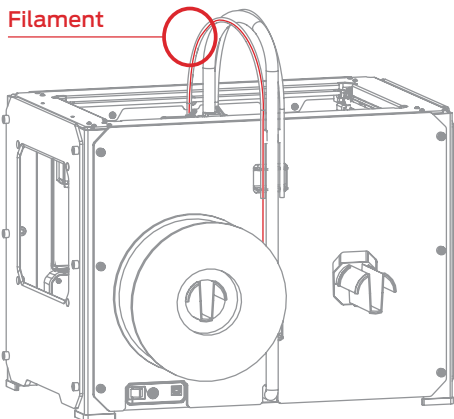

NOTE: To avoid filament jams, always ensure that any filament spool you mount on the Makerbot Replicator 2X feeds from the bottom of the spool toward the top. Filament mounted on the right spool holder [when viewed from the back] should always unspool clockwise and filament loaded onto the left spool holder should always unspool counterclockwise.

LOADING MAKERBOT FILAMENT CONTINUED

4. Run the Filament Loading Script

Use the LCD panel to navigate to **Utilities > Change Filament > Load Right** or **Load Left**. Then press the M button to start the process.

NOTE: The loading filament section of the startup script only walks you through loading the right extruder.

The MakerBot Replicator 2X will start to heat the selected extruder.

⚠ CAUTION: Do not touch the extruders while they are heating — they heat to 230° C.

5. Press the M to Continue

After the extruder reaches 230° C, the LCD panel will prompt you to load filament into the extruder. Press through the message until your MakerBot Replicator 2X asks you to press the M when you see plastic extruding.

6. Push the Filament into the Extruder

Take the end of the plastic emerging from the end of the filament guide tube and firmly push it into the hole in the top of the extruder. Ensure that the filament goes into the center of the opening and doesn't get caught at the edge of the opening.

Maintain pressure on the filament and continue pushing it into the opening. After about five seconds, you should begin to feel the motor pulling in the

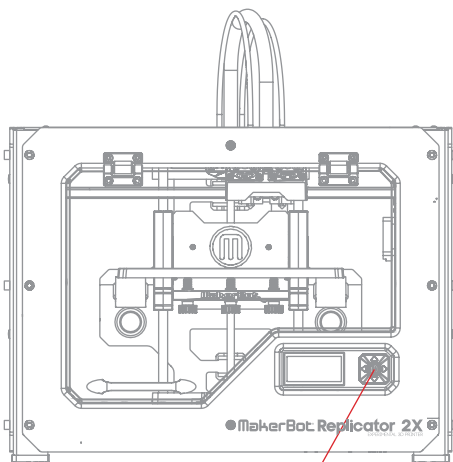

Press the M

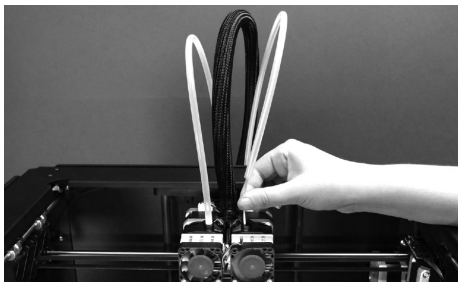

LOADING MAKERBOT FILAMENT CONTINUED

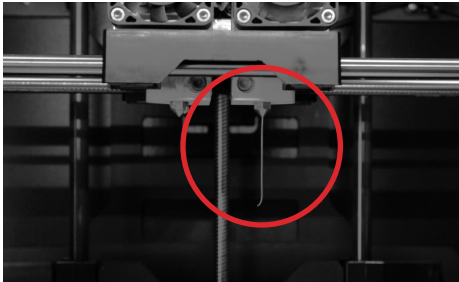

filament. Maintain pressure for another five seconds and then let go.

7. Stop Extrusion

After a few moments, you should see a thin string of plastic come out of the extruder nozzle. The filament might curl and then straighten; this is normal. Press the M button to stop extrusion.

NOTE: Don't be surprised if the plastic that initially comes out of the nozzle is not the color you expected. This is filament left over from testing. Wait until you see the color that you loaded come out of the nozzle before you press the M button.

8. Reattach the Filament Guide Tube

Push the guide tube back into the opening on the top of the extruder.

9. Remove the Extruded Plastic

Wait a few minutes for the extruded plastic to cool, then pull it away from the extruder nozzle. You can discard this extra plastic.

⚠ CAUTION: Do not touch the nozzle; it may still be hot.

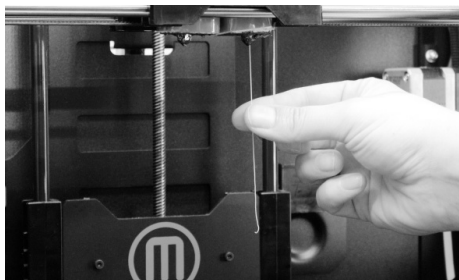

Don't leave plastic clinging to the extruder nozzles. This can cause newly-extruded plastic to stick to the nozzles instead of the build plate.

LOADING MAKERBOT FILAMENT CONTINUED



```
>Load right
  Unload right
  Load left
  Unload left
```

Unloading MakerBot ABS Filament

Just like with loading filament, the MakerBot Replicator 2X will heat the selected extruder to 230° C and then direct you to pull the filament free of the extruder.

To unload filament, navigate to **Utilities > Filament Options > Unload Right** or **Unload Left** on the LCD panel.



MAKERBOT DESKTOP

MakerBot Desktop is a free app for preparing 3D prints and managing your 3D content. Use MakerBot Desktop to explore Thingiverse®, organize your files, and prepare 3D models for printing.

DOWNLOADING & INSTALLING MAKERBOT DESKTOP

1. Open a browser session and go to makerbot.com/desktop.
2. Click **Download**.
3. Select your operating system from the dropdown menu and again click **Download**. A system-specific installer will download to your computer.
4. Double-click the MakerBot Desktop installer to run the installation wizard. Follow the installation instructions.
5. When you open MakerBot Desktop for the first time, you will go through a short setup process:
 - A. First, MakerBot Desktop will walk you through a quick tutorial of its features.
 - B. Next, you'll be asked how you want to connect MakerBot Desktop to your MakerBot Replicator 2X.
 - If you want to print by exporting files to an SD card, click **Skip**, choose **The Replicator 2X** as your type of printer from the dropdown menu, then click **Next**.
 - If you want to print via USB cable, connect your MakerBot Replicator 2X via USB cable now. MakerBot Desktop will automatically detect your printer.
 - C. Last, you'll be asked to either Sign in to MakerBot Desktop or to Create an Account. If you have a MakerBot Thingiverse account or a MakerBot Store account, you already have



DOWNLOADING & INSTALLING MAKERBOT DESKTOP

CONTINUED

a username and password. If not, you can create one now. This is your MakerBot account, and you can use it to log into MakerBot Desktop, Thingiverse, and other MakerBot sites. You can use MakerBot Desktop without logging in, but logging in will allow you to access your MakerBot Cloud Library and additional features in the Explore, Prepare, and Store sections.

You're now set up and ready to print!

ABOUT MAKERBOT DESKTOP

MakerBot Desktop is a free app for preparing 3D prints and managing your 3D content. It consists of five sections: **Explore**, **Library**, **Prepare**, **Store**, and **Learn**.

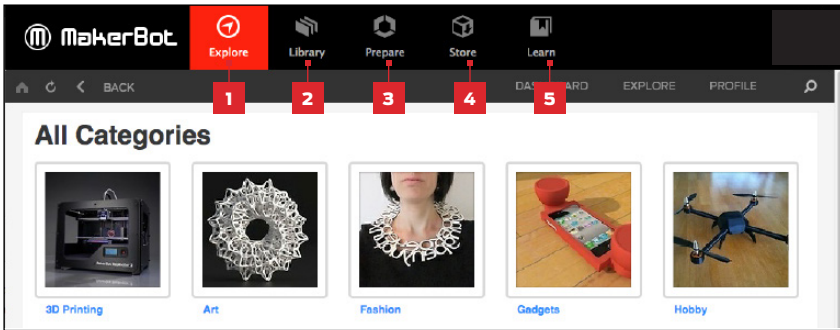

1. Explore gives you access to MakerBot Thingiverse and the hundreds of thousands of 3D printable objects designed by the Thingiverse community. Use Explore to search Thingiverse for inspiration or for new things to print, then save them to your collections or prepare them for printing.

2. Library gives you access to your MakerBot Cloud Library and helps you organize your 3D model files. Use it to access things you've collected on Thingiverse as well as your own models.

3. Prepare is where you will turn 3D models into print files. Bring 3D models into the Prepare screen to manipulate them on a virtual build plate. Then specify print options and either save the print files to an SD card or send them directly to your MakerBot Replicator 2X via USB cable.

4. STORE lets you buy print files for premium 3D models. The MakerBot Digital Store sells original, fun, and collectible digital content specifically for 5th Generation MakerBot Replicator Desktop 3D Printers and for the MakerBot Replicator 2. The MakerBot Digital Store does not currently offer files for the MakerBot Replicator 2X.

5. Learn provides video tutorials on common processes such as Exporting Files, Preparing to Print, and Exploring Thingiverse. Look for new tutorials with each update of MakerBot Desktop. You can also replay the MakerBot Desktop walkthrough in the Learn tab.

Use **Store** and **Explore** to find 3D models, **Library** to keep them organized, and **Prepare** to send them to your MakerBot Replicator 2X for printing. Use **Learn** to view tutorials.

THE PREPARE SCREEN

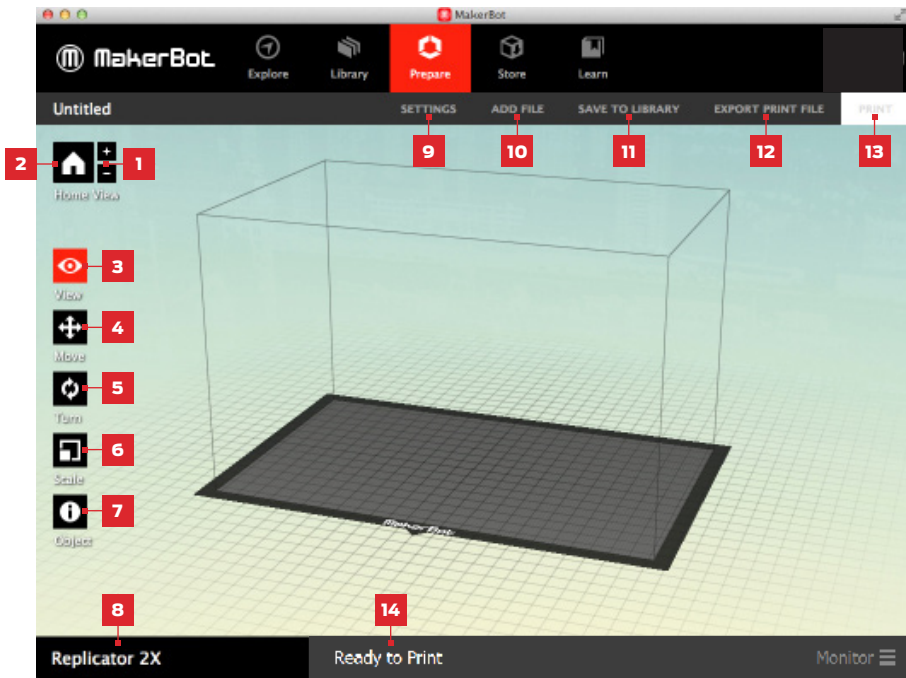

1. +/-

- Click the **Plus** and **Minus** buttons to zoom in and out.
- You can also zoom using a track pad or the scroll wheel on your mouse.

2. Home View

- Click the **Home View** button to return to the default view of the build plate.

3. View

- Click the **View** button or press the V key to enter View mode.
- In View mode, click and drag with your mouse to rotate the build plate.
- In View mode, hold the Shift key and click and drag with your mouse to pan.
- Click the View button again to open the Change View submenu and access preset views.

4. Move

- Click the **Move** button or press the M key to enter Move mode.

THE PREPARE SCREEN CONTINUED

- In Move mode, click and drag with your mouse to move your model around on the build plate.
- In Move mode, hold the Shift key and click and drag with your mouse to move your model up and down along the z-axis.
- Click the Move button again to open the Change Position submenu and move your object by a specific distance along the X, Y, or Z-axis.

5. Turn

- Click the **Turn** button or press the T key to enter Turn mode.
- In Turn mode, click and drag with your mouse to rotate your model around the z-axis.
- Click the Turn button again to open the Change Rotation submenu and rotate your object by a specific number of degrees around the X, Y, or Z-axis.

6. Scale

- Click the **Scale** button or press the S key to enter Scale mode.
- In Scale mode, click and drag with your mouse to shrink or enlarge your model.
- Click the Scale button again to open the Change Dimensions submenu and scale your object by a specific amount along the X, Y, or Z-axis.

7. Object

- Click the **Object** button twice or press the O key twice to open the Object submenu.
- Select which extruder you would like to print each object on your build plate.
- You can set each extruder's display color by navigating to **Edit > App Settings** in MakerBot Desktop.
- To have all objects printed by the same extruder, select the appropriate extruder and then click **Select All**.

8. File Name

- The File Name bar displays the name of the file or layout currently open.

9. Settings

- Click **Settings** to open the settings dialog.
- Use the dialog to change print settings for the current model or layout.

10. Add File

- Click **Add File** to open an Open File dialog.
- Navigate to the location of any STL, OBJ, or Thing file and select the file to add a model to the build plate.

THE PREPARE SCREEN CONTINUED

- Add as many models to the plate as you like. Use the keyboard shortcut Ctrl/Command + L to automatically arrange multiple models on the plate.
- Duplicate models already on the plate using the Copy and Paste options in the Edit menu or the keyboard shortcuts Ctrl/Command+C and Ctrl/Command+V.

11. Save to Library

- Click **Save to Library** to open a Save dialog.
- If you are logged into your MakerBot account, you can choose to save to your Library or to your local computer.
- If you are not logged into your MakerBot account or if you are working offline, you will be able to save your file only to your local computer.
- If you are working in an existing Thing file, you can rearrange the models on the plate and save this new layout to the Thing file without overwriting earlier layouts.

12. Export Print File

- Click **Export Print File** to slice your print and save the file to your local computer or SD card. Be sure to save the file as a .X3G. After the model has sliced, you can click Print Preview to open a preview of the sliced model.

13. Print

- The **Print** button functions only when your MakerBot Replicator 2X is connected via USB.
- Click Print to slice your file and send the file to your printer. After the model has sliced, you can click **Print Preview** to open a preview of the sliced model.

14. Status

- The status bar displays the connection status of any connected MakerBot 3D Printer.
- The status bar displays the progress of the current print.
- Click the menu icon at the right side of the status bar to open a print monitor panel, which will display more detailed information about your MakerBot Replicator 2X and any print in progress.
- Open the print monitor panel to pause or cancel a print.

4

PRINTING WITH YOUR MAKERBOT REPLICATOR 2X

This chapter will walk you through finding a model to print, preparing that model, and then finally printing the model.

This chapter assumes you have already downloaded and installed MakerBot Desktop. If you have not installed MakerBot Desktop, see the section in chapter 3 on Downloading and Installing MakerBot Desktop.

CHOOSING A MODEL

You can download a model from Thingiverse, open a 3D printable **.STL**, **.OBJ**, or **.Thing** file from any source, or access objects that are already saved in your MakerBot Cloud Library.

FINDING A MODEL ON THINGIVERSE

1. In MakerBot Desktop, click on the **Explore** tab. Click Explore at the right to browse available models, or use the search bar to look for something specific.
2. Click the thumbnail or name of any Thing to go to the Thing page.
3. On the Thing page, scroll down and click on **Thing Files** to see available files.
4. Choose which part or version you want to print and click the Prepare button next to the file name. MakerBot Desktop will open the file and take you to the Prepare tab. The file you selected will appear on the build plate.
5. To add an additional model from the same Thing to your layout, return to the Explore tab and click **Prepare** next to the name of the additional file. The new model will be added to the plate.

IMPORTING A MODEL FROM YOUR LOCAL COMPUTER

You can open any 3D-printable STL, OBJ, or Thing file in MakerBot Desktop.

1. In MakerBot Desktop, click on the **Prepare** tab.
2. Click **Add File**.
3. Navigate to the location of your file and click **Open**. The model will appear on the build plate.

CHOOSING A MODEL FROM YOUR MAKERBOT CLOUD LIBRARY

1. In MakerBot Desktop, click on the **Library** tab.
2. Click one of the folders at the left side of the screen to see items available in your Library.
3. Click on a list item and then click **Prepare**. MakerBot Desktop will open the file and take you to the Prepare tab. The file you selected will appear on the build plate.

PREPARING A MODEL

Use the **Move**, **Turn**, and **Scale** buttons in the **Prepare** tab to position and scale your model on the virtual build plate.

BASIC SETTINGS

If you want to change any settings before printing, click Settings. This is where you can specify options that will affect the quality of your printed object, like print resolution and object strength. To print with standard or previously specified settings, skip this step and go straight to printing.

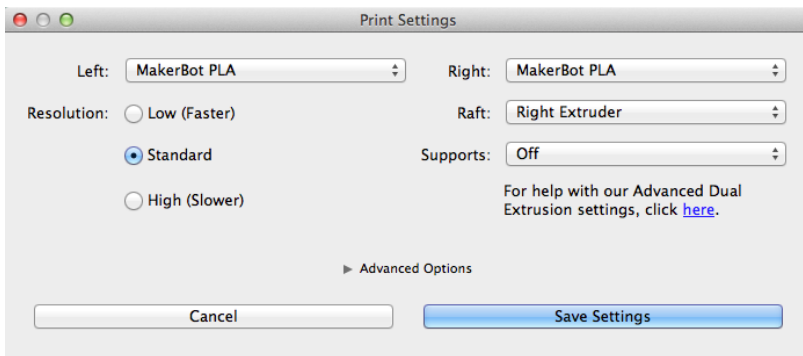

1. Filament Type

Set each extruder to the type of filament you plan to print with. If you are not printing with dual extrusion, MakerBot Desktop will ignore the filament type set for the unused extruder.

2. Resolution

Choose **Low**, **Standard**, or **High** resolution to specify the surface quality of your 3D print.

- Objects sliced with the Standard resolution profile will be printed using the default settings. Standard resolution prints will print quickly and have good surface quality.
- Objects sliced using the Low resolution profile will be printed with thicker layers and will print faster.
- Objects sliced with the High resolution profile will have finer layers and will print more slowly.

3. Raft

Choose if you want your object to print with a raft. The raft acts as a base for your object and any support structures, and ensures that everything adheres well to the build plate. The raft will be easily removable once you remove your finished object from the build plate.

PREPARING A MODEL CONTINUED

Use the Raft drop-down box to choose from these options:

- Choose **Off** to turn off the raft.
- Choose **Left Extruder** or **Right Extruder** to have the raft printed only using the left or right extruder.
- Choose **Color-Matched** to have the material of your raft determined automatically. If you are printing a single-material object, the raft will automatically be printed with the same extruder. If you are printing a dual material object, the raft will be built from both materials so that each portion of your object will only touch raft of the same color.

4. Supports

Choose if you want your object to print with supports. MakerBot Desktop will automatically generate supports for any overhanging sections of your object. Supports will be easily removable once you remove your finished object from the build plate. Use the Supports drop-down box to choose from these options:

- Choose **Off** to turn off supports.
- Choose **Left Extruder** or **Right Extruder** to have supports printed only using the left or right extruder.
- Choose **Color-Matched** to have the material of your supports determined automatically. If you are printing a single-material object, supports will automatically be printed with the same extruder. If you are printing a dual material object, supports will be built from both materials so that each portion of your object will only touch support structures of the same color.

5. Advanced

Click **Advanced** for additional options, including temperature and object strength. For information on what the advanced settings are and how to use them, see **Chapter 5: Advanced Settings**.

6. Cancel

Click **Cancel** to return to the Prepare screen without saving changes. Any print settings you had selected will be discarded.

7. Save settings

When you are finished, click **Save Settings**. The current settings will be used to slice your model the next time you print or export a print file.

PREPARING A MODEL CONTINUED

DUAL EXTRUSION

Dual extrusion prints are composed of two STL files sliced to a single X3G file. You will designate one STL file to be printed by the right extruder, and the other STL file by the left extruder. Dual extrusion is great for when you want to print in two different colors, or with dissolvable filament for your raft and/or supports.

To better understand how to prepare a dual extrusion print, we will use an example object from Thingiverse.

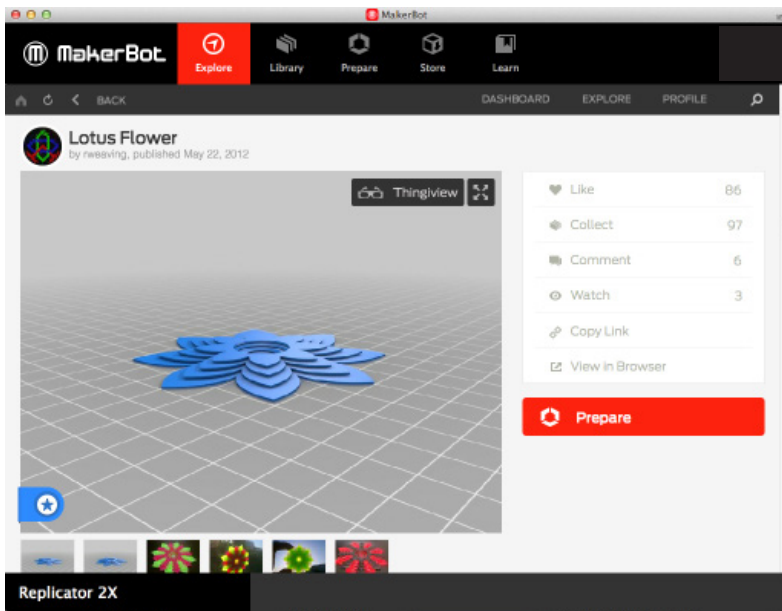

1. In MakerBot Desktop, click on the **Explore** tab.
2. In the Search field in the upper right of the page, enter “Lotus Flower.”
3. In the Search Result page, find Lotus Flower by rweaving. Click anywhere on the image.
4. In the Thing page for the Lotus Flower, click the **Prepare** button.
5. You will be directed to the bottom of the page where you will see each of the two STL

PREPARING A MODEL CONTINUED

files that make up the Lotus Flower. You will also see the Thing file that contains both STL files. Click on **Prepare** next to the Thing file.

6. Click on the point of an outer petal from the first layer to highlight that object.
7. Click twice on the Object button.

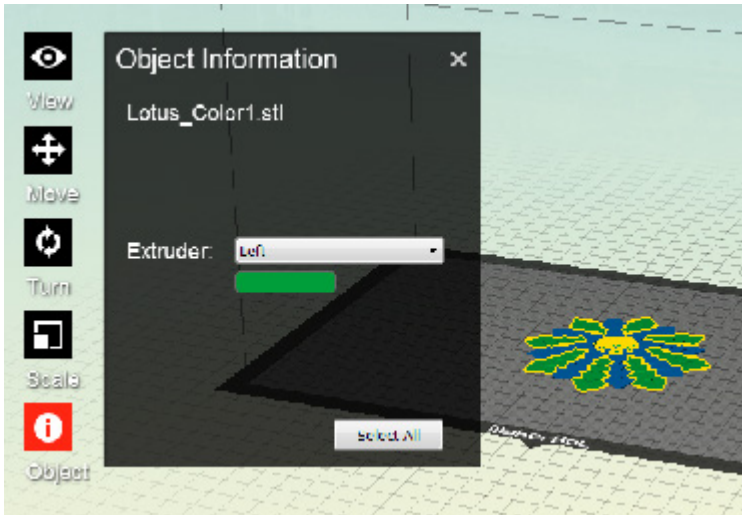

8. In the Object Information submenu, in the Extruder dropdown menu, select an extruder to print Lotus_color2.stl.
9. Click on the point of an outer petal from the second layer to highlight that object.
10. Click twice on the Object button.
11. In the Object Information submenu, in the Extruder dropdown menu, select the other extruder to print Lotus_color2.stl.

NOTE: To change the display colors of your extruders, go to **Edit > App Settings** in MakerBot Desktop.

PRINTING A MODEL

Once you've saved your settings in MakerBot Desktop, it's time to print. Your MakerBot Replicator 2X can print via SD card or via USB.

FILE TYPES

MakerBot Desktop can open the following file types:

- OBJ
- STL
- THING

MakerBot Desktop can save the following file types:

- STL
- THING

MakerBot Desktop can export to the following file types:

- GCode
- X3G
- S3G
- .makerbot (for 5th Generation MakerBot Replicators only)

STL

An STL is a widely-used type of 3D model file. It consists of surfaces made up of triangles. Each triangle has an inner side and an outer side. The outer side is called the “normal.” In a well-formed STL, all the normals face outwards and the surface is continuous, with no holes. When a model meets these standards, it is referred to as “manifold.” STLs with normals that face inwards (inverted normals) may be printable, but manifold models are typically considered mandatory for 3D printing.

STLs are compatible with many different 3D modeling programs and have become the standard file type for 3D printable models. SolidWorks®, Rhinoceros®, and most Autodesk® programs will export STL files, and there are free plugins available that will allow you to export STLs from SketchUp®.

OBJ

An OBJ is another type of 3D model file. It is also used by a number of 3D modeling programs, but is used for 3D printing less often than STL. Unlike STLs, where every facet of your 3D model is a triangle, an OBJ can contain triangles and other polygons. Rhinoceros and some Autodesk programs will export OBJ files, but other programs, including SketchUp and SolidWorks, will require a plugin to export as OBJ.

THING

When you save a model or group of models in MakerBot Desktop, the default format for saving it will be a Thing file. A Thing file includes information about the orientation and position of each 3D model on the build plate. The file also allows you to include multiple models on the plate. When you save multiple models in a Thing file, you can continue to manipulate them individually. If you plate multiple models and save them in other formats, such as STL, you will no longer be able to move the

PRINTING A MODEL CONTINUED

individual models in relation to each other. The Thing format works only with MakerBot Desktop, so you should not save as Thing if you are saving a file for use with another program. If you have a Thing file and need to edit an individual STL file within it, change the file extension to .zip. Then unzip the file and extract the STL you need.

GCODE

GCode is a computer language for controlling CNC machines, including many 3D printers. When your slicing software turns your 3D model into a set of instructions for your MakerBot Replicator 2X, those instructions are written in GCode. The instructions consist of commands that tell the extruders how hot to get, where to move and when to start extruding plastic, commands that control the build platform and commands for peripheral components, including the LEDs inside your MakerBot Replicator 2X. Before being sent to your MakerBot Replicator 2X, MakerBot Desktop converts the human-readable GCode to the more compact, computer readable X3G.

X3G

X3G is the compact format in which MakerBot Desktop sends instructions to your MakerBot Replicator 2X. An earlier version of this format was called S3G.

PRINTING A MODEL CONTINUED

PRINTING VIA SD CARD

1. Place an SD card in the SD card slot of your computer. The SD card must be:
 - Formatted for FAT16
 - No larger than 2GB
2. In MakerBot Desktop, click **Export Print File**. MakerBot Desktop will slice your model.
3. Once your model is sliced, a dialog will appear with an estimated print time and estimated filament usage, as well as an opportunity to view a print preview.

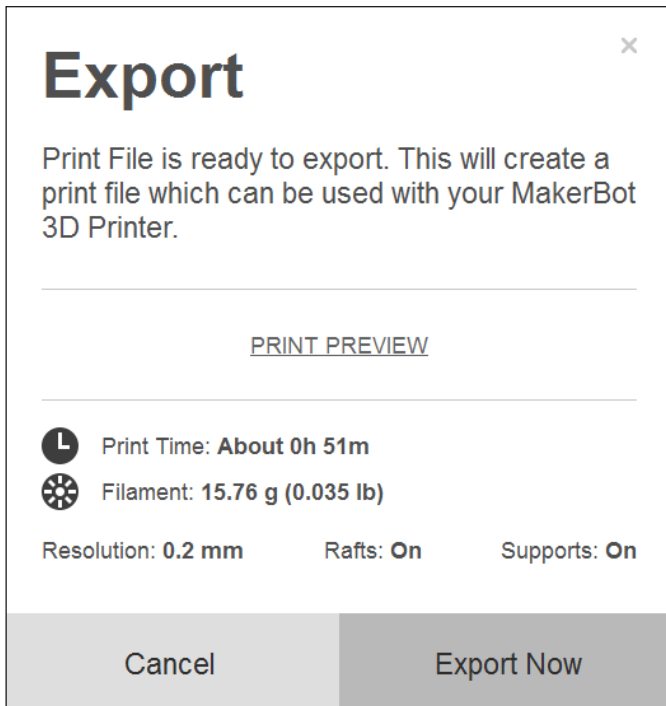

4. Click **Export Now** to open a save dialog.
5. Name your X3G file, navigate to the SD card, and click **Save**.

PRINTING A MODEL CONTINUED

6. Once the file is saved to the SD card, eject the SD card from your computer and insert it into the SD card slot at the top of the LCD panel on your MakerBot Replicator 2X.
7. From the home screen on the LCD panel, use the up arrow button to navigate to **Build from SD**, and then press the M button.
8. Use the up and down arrow buttons to find your particular .x3g file. When you find it, press the M button to start printing.

PRINTING VIA USB

1. Insert the USB-B end of the cable into the port on the back of your MakerBot Replicator 2X and insert the USB-A end of the cable into a USB port on your computer.
2. In MakerBot Desktop, click **Print**. MakerBot Desktop will slice your file and send it to your MakerBot Replicator 2X to print. A dialog will appear with an estimated print time and estimated filament usage, as well as an opportunity to view a print preview.

POST PRINT STEPS

Remove Raft and/or Supports

When your print finishes, wait for the extruders to cool. Remove the print from the build plate, and peel off the raft from the bottom of the print. Remove any support material either with your fingers or with a tool like pliers.

Share on Thingiverse

If you printed a file from Thingiverse, it's nice to let the model's designer know. Return to the model's thing page in the Explore tab of MakerBot Desktop, and click on **View in Browser**, which will open up your default web browser to the model's thing page. Then click **I Made One**. You'll have the opportunity to upload a photo of your print and add a description. When you're ready, click **Create** to link your photo to the original design's thing page.



ADVANCED SETTINGS

This chapter describes the advanced printing options in MakerBot Desktop.

ADVANCED OPTIONS

To use the settings under **Advanced Options**, you must select one of MakerBot Desktop's base profiles (Low, Standard, or High). When you change any of the settings in **Advanced Options**, an asterisk will appear next to the profile name in the Settings dialog. The asterisk indicates that the base profile is no longer in its default state.

These options provide control over specific slicing options. To access the advanced options, click the **Advanced Options** button towards the bottom of the Settings dialog. This button toggles the visibility of the advanced options, which are grouped into three tabs: **Quality**, **Temperature** and **Speed**.

To change a setting in the **Advanced Options** tabs, highlight the current number and enter a new one, or use the up and down arrows to incrementally change the values.

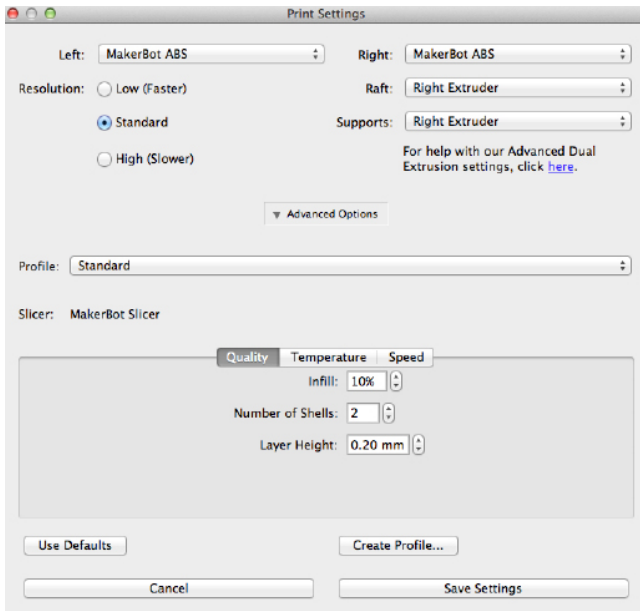

NOTE: The settings in Advanced Options do not edit the base profiles; they only override them. MakerBot Desktop will save the set of overrides for you, but you can always return the profile to its original state by clicking the **Use Defaults** button at the lower left of the Advanced Options area.

QUALITY

The settings in the **Quality** tab affect the strength and finish of printed objects. Each Quality option affects particular sections of an object.

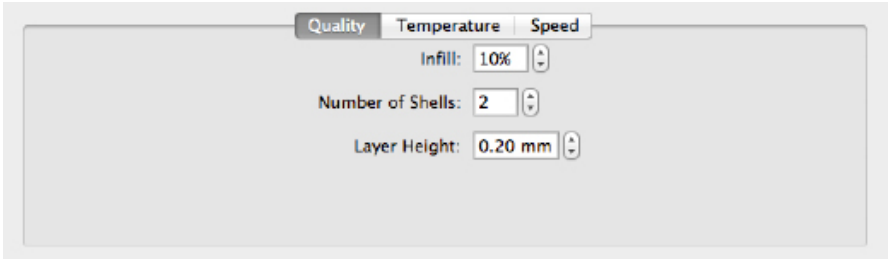

INFILL

Infill provides your object with an internal support structure. The number that you enter in this field defines the solidity of the printed object's infill. Higher infill percentages will result in more threads of infill extrusion that are closer together, increasing the strength and weight of your object. Lower infill percentages will result in fewer threads of infill extrusion that are more widely spaced. For a hollow object with no internal support structure, enter an infill of 0%. For a completely solid object, enter 100%.

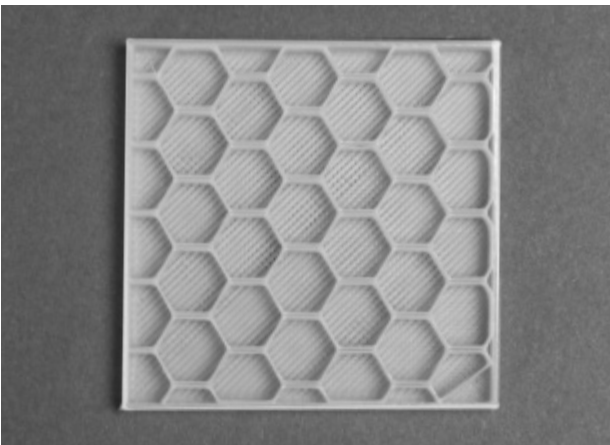

File Name: 20mm calibration box

Design by: SpaceXula

Thingiverse: 2064

SHELLS

The MakerBot Replicator 2X starts each new layer of an object by printing some number of outlines of that layer. These are called shells. Every object you print must have at least one shell. If there is more than one shell, the additional shells will be nested inside the first one. You can add as many shells as you want and they will print as concentric perimeters on each layer. If the layer cannot accommodate the specified number of shells, the slicer will just fit in as many as possible.

Additional shells, like larger amounts of infill, add to an object's strength, weight, and print time. Two or three shells are sufficient for most objects. Additional shells might help if you see cracks between the layers of your object.



File Name: Rock Wall hold 1.0

Design by: Jeremy007007

Thingiverse: 34331

LAYER HEIGHT

Layer height determines the thinness of each printed layer of your object. It is often treated as a measure of resolution in 3D printing, but it affects resolution only on the Z-axis (up and down).

Thinner layers will result in a smoother surface, but will also increase print times; layers take the same time to print regardless of height, and thinner layers increase the total number of layers to be printed.

TEMPERATURE

Temperature settings for the extruders and the build plate are grouped together under the Temperature tab.

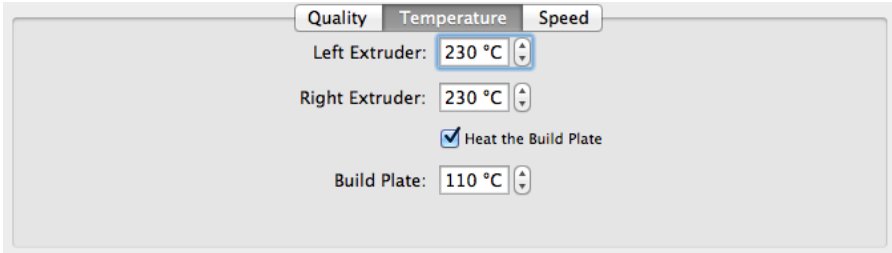

EXTRUDERS

The extruders will need to be heated to approximately 230° C to melt and extrude the plastic filament at normal operating speeds. Extrusion temperature is tied very closely to both extrusion speed and the material being extruded. If you are experimenting with either of those, you might need to experiment with extrusion temperature, too.

BUILD PLATE

A heated build plate helps printed plastic objects to stick to the printing surface without warping. If prints are not adhering to your build plate, and you have tried cleaning and releveling, try raising the plate temperature a few degrees.

ABS adheres best at temperatures between 100° and 115° C. If you adjust the plate temperature to 115° C and continue to have adhesion problems, the problem probably lies elsewhere.

SPEED

Everyone wants their MakerBot to move faster so they can print things more quickly. Our default print speed is 80 mm/s, and if you want to print faster, you might have to adjust more settings than the extrusion speed. Print speeds are closely tied to temperature settings and to the mechanical capabilities of your MakerBot Replicator 2X.

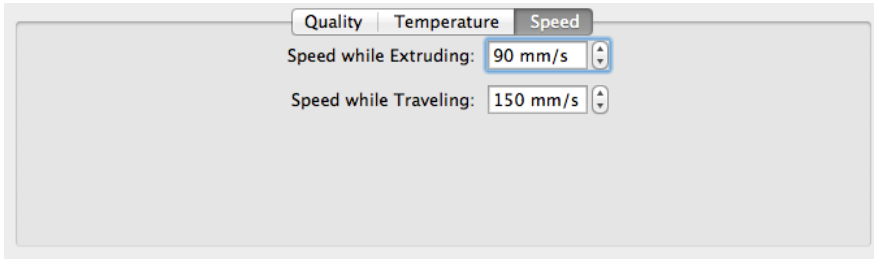

SPEED WHILE EXTRUDING

Speed while Extruding controls two things: the speed at which the extruder is moving while printing and the speed at which plastic is coming out of the nozzle. These speeds are the same because that makes for the most even extrusion.

Because moving filament through the extruder at higher speeds pulls heat out of the extruder more quickly, substantial increases in speed require increases in extrusion temperatures. MakerBot does not recommend extruder speeds higher than 120 mm/s.

SPEED WHILE TRAVELING

Traveling is when the extruder moves without extruding filament. Because travel moves are not limited by the temperature at which the plastic can be extruded, they can be faster than moves that do include extrusion.

CUSTOM PROFILES

Additional advanced options are available through Custom Profiles. Custom profiles allow you to edit the slicing engine's profile settings directly instead of overriding them by using the Advanced Options settings. Visit the Using **Custom Slicing Profiles** page at www.makerbot.com/support/new/Desktop for more information.



MAINTENANCE

We've made the MakerBot Replicator 2X incredibly easy to take care of, but there are a couple of things you'll want to do from time to time to keep it running as smoothly as possible.

LEVELING THE BUILD PLATE

One of the best things you can do to keep your MakerBot Replicator 2X in top shape is to level your build plate frequently. It never hurts to re-level, but forgetting to do so can hurt your success rate.

Please see page 26 to learn how to level the build plate using the onboard leveling script.

To level the build plate without using the built-in script:

1. Using the LCD panel, navigate to **Utilities > Home Axes**.
2. Manually move the extruders to different points above the build plate. At each point, use a piece of paper, feeler gauge, or other measuring tool to gauge the distance between the build plate and extruder nozzles. The distance should be about 75% of your planned layer height.
3. At each point, turn the closest leveling knob beneath the build plate to the left to raise the build plate and to the right to lower it.

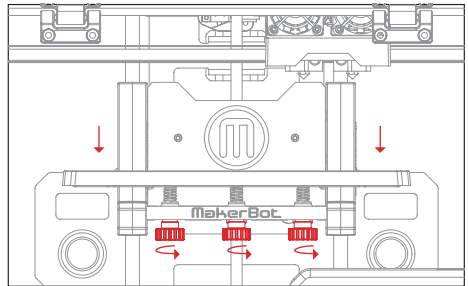
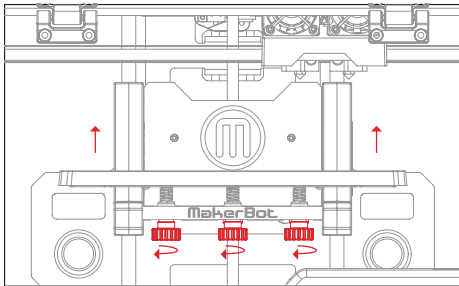

You should level your build plate regularly, especially if you notice that your extruder nozzle is scratching the build plate, or that the first layer of an object doesn't adhere to the plate. Each time you level, you should also make sure that your build plate is clean: dust, scratches and oil from your hands can cause some of the same problems as a plate that's too far from the extruder.

LEVELING THE BUILD PLATE CONTINUED

Here are a few tips to keep in mind when you level your build plate:

- Make sure to take your fingers off the leveling knobs and platform when you test the friction on your paper or feeler gauge; pressure from your hands can affect platform height.
- If you're having trouble leveling your build plate, make sure your nozzles are clean. Small amounts of plastic stuck to the nozzles can make it feel like the nozzle is closer to the plate than it really is. Wrinkles in the Kapton tape can also yield confusing results.
- Printing at lower layer heights might require the plate and nozzle to be a little closer together. If you are printing at a lower layer height than you were previously and the first layer of your print isn't sticking well to the plate, try turning each leveling knob about a quarter turn to the left.

REPLACING KAPTON TAPE

Over time, the Kapton tape on your build plate will be scratched and torn, and you will need to replace it with one of the die-cut Kapton sheets that was included in the package with your MakerBot Replicator 2X.

To replace the Kapton tape:

1. Peel off the old Kapton tape and discard it.
2. Locate the extra sheets of Kapton tape that were included with your MakerBot Replicator 2X. If you have used up these sheets, Kapton tape is available for purchase at store.makerbot.com/parts-accessories.html.
3. On one of the short sides of the sheet, peel back the plastic backing approximately 1/4 inch from the edge, so that 1/4 inch of the sticky side of the Kapton tape is exposed.
4. Place the exposed strip of Kapton tape along the edge of one of the short sides of the build plate. Use your finger to apply pressure and adhere the Kapton tape to the build plate.
5. Use the tape applicator that was included with your MakerBot Replicator 2X to simultaneously roll back the plastic backing bit by bit and smooth the newly exposed Kapton tape as you go. Make sure to smooth out any bubbles.



6. Continue smoothing the tape down bit by bit until you have covered the entire plate.
7. If there are still bubbles under the Kapton tape, lift the edge of the tape that is nearest to the bubbles and use the tape applicator to smooth the tape from the center out.

REPLACING KAPTON TAPE CONTINUED

8. When the Kapton tape is applied as smoothly as possible, trim the edges of the sheet or fold them over the sides of the build plate.

NOTE: To view a video of this process, visit mbot.co/1u9NCuC.

LUBRICATING THE Z-AXIS ROD & IDLER PULLEY

After approximately 50 hours of build time, you should lubricate the threaded rod on your Z-axis and the X-axis idler pulley.

To lubricate the threaded rod and the idler pulley:

1. Find the tube of PTFE-based grease included in the package with your the MakerBot Replicator 2X. If you have used up this tube of grease, PTFE-based grease is available for purchase at store.makerbot.com/parts-accessories.html
2. Grasp both sides of the build platform and push it gently to the bottom of the MakerBot Replicator 2X.
3. Use a clean, lint-free rag [or your finger] to spread the PTFE-based grease onto as much of the threaded rod as you can reach. Make sure you get the grease inside the threads themselves.



4. Grasp both sides of the build platform and move it to the top of the MakerBot Replicator 2X.
5. Use a clean, lint-free rag [or your finger] to spread the PTFE-based grease onto the bottom section of the threaded rod. Make sure you get the grease inside the threads themselves.
6. Locate the X-axis idler pulley. Facing the front of the MakerBot Replicator 2X, the idler pulley is at the top left. The idler pulley is one of the pulleys that allow the rubber belt to move the extruder from left to right, or along the X-axis. The pulley at the other side of the gantry is called the timing pulley and does not require lubrication.

LUBRICATING THE Z-AXIS ROD & IDLER PULLEY

CONTINUED

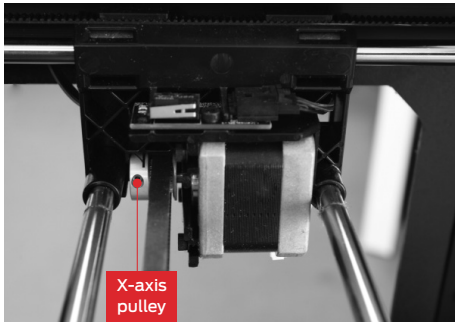

7. Squeeze a small amount of the PTFE-based grease directly onto the exposed area of the metal rod inside the idler pulley and manually move the pulley back and forth to spread the grease.

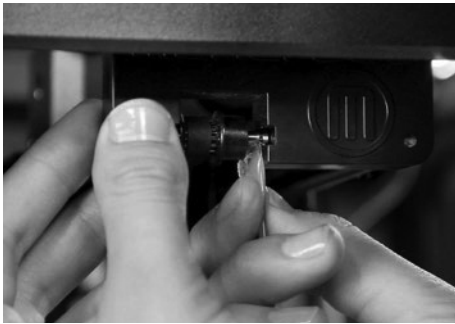

NOTE: To view a video of this process, go to visit mbot.co/1u3YfTc.

REALIGNING THE GANTRY

The gantry is the system of rods and belts that moves the extruder. If one side is too far out of alignment with the other, the outlines of printed objects might appear slanted on the build plate. You should make sure your gantry is aligned after moving or jolting your MakerBot Replicator 2X.

To determine whether your gantry is aligned correctly, push the extruders all the way to the front of the MakerBot Replicator 2X. Hold the right side of the gantry against the front of the MakerBot Replicator 2X. Then try pushing the left side forwards. It should not move. If it does move, perform the following steps.

1. Turn off the MakerBot Replicator 2X.
2. Unscrew the bolts on each of the MakerBot Replicator 2X side panels. Set the bolts and panels aside.
3. Locate the four pulleys holding the Y-axis belts. There is one pulley in each corner of the upper frame of the MakerBot Replicator 2X. You will see two pulleys in the back right corner of the MakerBot Replicator 2X. You will be adjusting the pulley closer to the center of the MakerBot Replicator 2X.
4. For each pulley, manually move the extruders backwards or forwards to rotate the pulley until you have a clear view of the set screw holding the pulley to the front or back gantry rod. Use the 1.5 mm hex wrench from the accessory box to loosen each set screw.

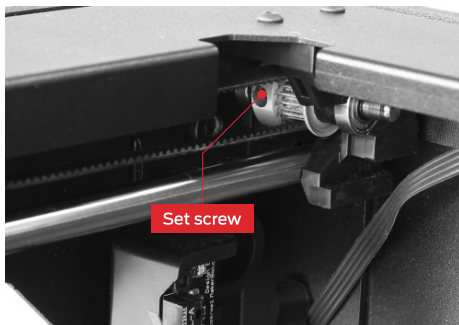

REALIGNING THE GANTRY CONTINUED

5. Manually move the extruders to the front of the MakerBot Replicator 2X, as far forward as they will go. Make sure that the plastic pieces on both sides of the gantry are flush against the plastic brackets that hold the two front pulleys.
6. Use the 1.5 mm hex wrench to tighten the set screw in each of the two back pulleys. Make sure these set screws are very tight.

NOTE: If you cannot see one of the set screws, hold both sides of the gantry and gently push it away from the front of the MakerBot Replicator 2X. Make sure to exert an equal amount of pressure on both sides of the gantry. Push only until you can see the hidden set screw.

1. Manually move the extruders toward the back of the MakerBot Replicator 2X. Make sure the gantry is as far back as it can go.
2. Use the 1.5 mm hex wrench to tighten the set screw in each of the two front pulleys. Make sure these set screws are very tight.

NOTE: If you cannot see one of the set screws, hold both sides of the gantry and very gently push it away from the back of the MakerBot Replicator 2X. Make sure to exert an equal amount of pressure on both sides of the gantry. Push only until you can see the hidden set screw.

When you have completed these steps, your gantry will be correctly aligned again.

NOTE: To view a video of this process, visit mbot.co/1toY5nP.

TIGHTENING THE X AND Y-AXIS PULLEYS

Loose X and Y-axis pulleys in your MakerBot Replicator 2X can result in belts slipping during printing. If you notice shifts on the X or Y-axis during a print, it might be time to tighten your pulleys.

1. Locate the X-axis pulley. It is attached to the motor mounted on the right side of the gantry. Slide the extruders to the left until you have access to the set screw holding the pulley to the motor shaft. Use the 1.5mm hex wrench from the accessory box to tighten the set screw.

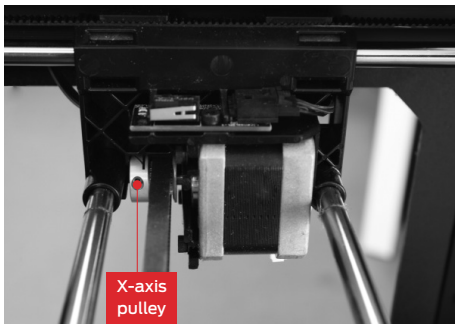

2. Locate the Y-axis pulley. It is attached to the motor mounted in the back right corner of the Makerbot Replicator 2X. Slide the extruders to the front of the Makerbot Replicator 2X until you have access to the set screw holding the pulley to the motor shaft. Use the 1.5mm hex wrench from the accessory box to tighten the set screw.

NOTE: To view a video of this process, visit mbot.co/1qZEutB.

FILAMENT CARE

Your MakerBot Replicator 2X Experimental 3D Printer is optimized to print with 1.75 mm MakerBot ABS plastic filament. For maximum performance, you must keep your ABS filament cool and dry. Heat and humidity can cause the ABS plastic to absorb moisture and swell. To reduce the absorption of moisture, keep the filament in a sealed plastic bag when not in use.

Keep your filament tightly wound on the spool. Loose filament will become tangled, and can break or jam during a print.



TROUBLESHOOTING

PRINTING ISSUES

Objects Do Not Stick to the Build Plate

If printed objects are not sticking to the build plate, try these solutions:

- Re-level your build plate by navigating to **Utilities > Level Build Plate** on the LCD panel. Inconsistent plate height will lead to inconsistent adhesion. If any one part of your object does not adhere well to the plate, the whole object might peel off the plate. Try leveling the plate again using a thinner piece of paper or feeler gauge to check the distance between the nozzle and the build plate.
- Ensure that the plate is clean. Bubbles, scratches, dust, and oil from your hands can prevent objects from sticking to the Kapton tape. Wipe down the build plate with a clean, lint-free cloth.
- Increase the temperature of the build plate by five degrees. You can change the temperature of the build plate in the **Advanced Options** section of the **Settings** dialog in MakerBot Desktop.
- If you continue to have adhesion problems, loosen each of the plate-leveling knobs about a quarter of a turn to bring the plate slightly closer to the nozzles.

Objects Are Difficult to Remove from the Build Plate

If printed objects are difficult to remove from the build plate, try these solutions:

- Wait for the build plate to cool down. Objects will detach more easily when both the plastic and the plate are cool.
- Use a metal craft spatula and carefully work the blade under the edge of the object. When the blade is fully under the object, twist the handle slightly. The object should come free.

EXTRUSION STOPS

There are a few problems that can cause your MakerBot Replicator 2X to stop extruding. Use this checklist to determine the cause and appropriate solution.

- **Is your extruder motor rotating?** Use a marker to draw a line across the end of the motor shaft that is visible at the back of the motor. When the extruder is running, you should be able to see the shaft turning. The shaft may sometimes reverse direction in order to retract filament, but during extrusion it should be moving at a slow but constant rate. If the shaft does not turn, or stops turning, please visit makerbot.com/support/new/support to learn what your support options are.

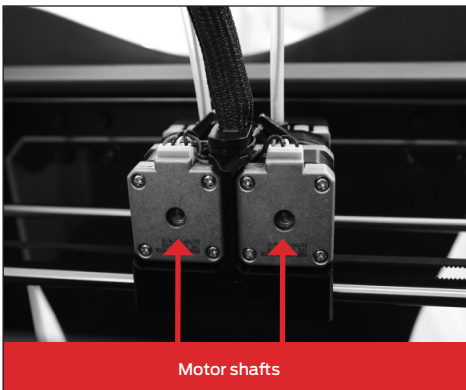

- **Is your filament tangled?** Check that the spool is spinning smoothly on the mount.
- **Is the build plate too close to the extruder?** If so, there might not be room for the plastic to come out of the extruder. If your extruder stops extruding during the first or second layer of a build, this usually indicates that the build plate is too close to the extruder.
- **Is the nozzle clogged?** Go to the LCD menu on your MakerBot Replicator 2X and navigate to **Utilities > Change Filament > Load right** or **Load left**. Run the Load script. Observe the plastic as it emerges from the nozzle. Does it drop straight down, or curl up toward the extruder? If it curls back up toward the extruder, the nozzle may be partially clogged. See the section Filament Stuck on page 71 for more help.

REPLICATOR 2X SHAKES

Your Replicator 2X will shake during printing if you print at high speeds with acceleration turned off. Attempting to print at high speeds with acceleration turned off can harm your MakerBot Replicator 2X. To check and change the Acceleration setting, go to the LCD menu on your Replicator MakerBot 2X and navigate to **Info and Settings > General Settings > Accelerate**. You can turn acceleration off and on. Acceleration is turned on by default. If you have acceleration turned off, you should not print at speeds above 40 mm/s.

FILAMENT NOT LOADING

If you are having problems loading filament into one of the extruders, perform the following steps:

1. Using the LCD panel, navigate to **Utilities > Filament Options > Unload**. This option heats the extruders.
2. Make a fresh cut at the end of the filament. It is important that the filament have no bends in it. If there are bends, cut off the bent section of filament.
3. Insert the filament into the hole at the top of the extruder. Keep pushing it in until you start to see plastic come out of the nozzle. You might have to apply some pressure.
4. When the filament is successfully loaded, set the extruder lever arm to the closed position.

If filament doesn't emerge from the nozzle, try the following solutions:

- Remove the filament from the top of the extruder and check for a bend at the end of the filament. If the filament is bent, it is possible that the filament is slipping under the extruder bearing instead of entering the hot end.
- Remove the extruder fan and assembly using the instructions in the section **Disassembling an Extruder**. This will allow you to watch the filament travel through the extruder and determine where the filament is getting stuck. This will also allow you to see if a piece of filament is stuck inside the extruder.

FILAMENT STUCK

Filament can swell inside the extruder and get stuck. If you cannot unload filament from one of the extruders, do the following:

1. On the LCD panel, navigate to **Utilities > Change Filament > Unload**. This option heats the extruders.
2. Set the extruder arm to the open position.
3. Push about half an inch of filament through the extruder to clear the blockage. Try pulling the filament out of the extruder again.

If you are unable to unload filament because it has broken off inside the extruder, you might not be able to reach inside the extruder to clear the blockage. In that case, see the section **Disassembling an Extruder**.

DISASSEMBLING AN EXTRUDER

1. Unload the MakerBot Filament from the extruder. To run the script for unloading filament, navigate to **Utilities > Change Filament > Unload** on the LCD panel.
2. Switch off the power on the MakerBot Replicator 2X and unplug the power supply. Pull on the connector to release it from the power input port.
3. Unscrew the two bolts at the lower corners of the fan guard using your 2.5 mm hex wrench. As one piece, remove the fan guard, the fan, the heat sink, and the spacers. Keep these pieces assembled and move them out of the way.
4. Unplug the motor wire harness from the top of the extruder motor and slide the motor assembly out of the extruder.

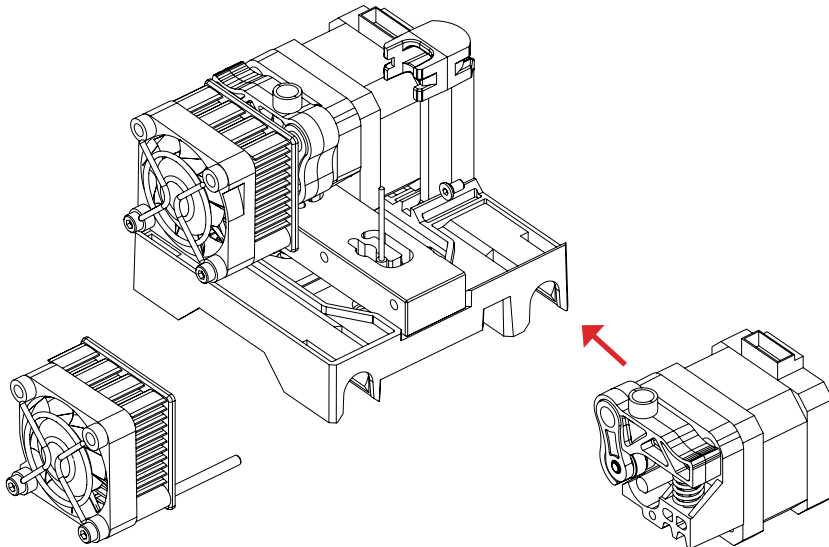





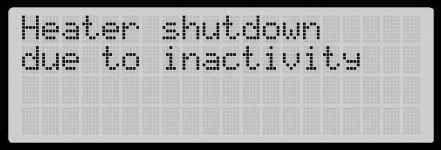

LCD ERROR MESSAGES

If your MakerBot Replicator 2X encounters problems during operation, the LCD menu will display an error message. The following table describes each possible error message.

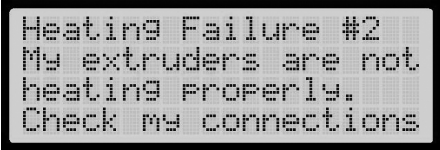

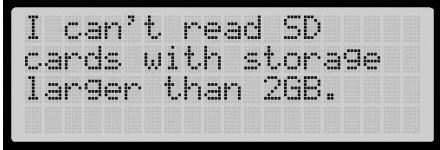

NOTE: If you see an error message in an unexpected context, submit a case to MakerBot Support at www.makerbot.com/support/submit-a-case/

Error Message	Description
	<p>Use the LCD menu to check your target extruder temperatures. Navigate to Info and Settings > Preheat Settings to make sure the extruder temperatures are not set higher than 300° C.</p> <p>If the extruder temperatures are set to below 300° C, visit makerbot.com/support/new/support to learn what your support options are.</p>
	<p>To clear this message, you will have to restart your MakerBot Replicator 2X.</p> <p>Your MakerBot Replicator 2X has automatically disabled its heaters after a period of inactivity as a safety precaution. Restart your print or the preheat routine to reset your heaters.</p>

LCD ERROR MESSAGES CONTINUED

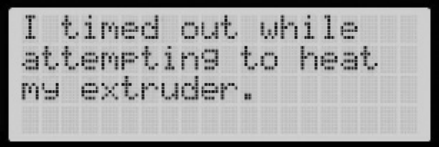
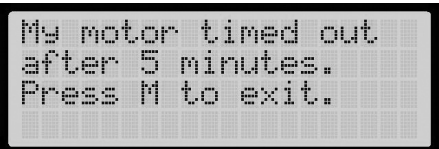
Error Message	Description
 <pre>Heating Failure #2 My extruders are not heating properly. Check my connections</pre>	<p>These messages indicate that your MakerBot Replicator 2X cannot read the temperature for one of the extruders.</p> <p>Ensure that the wires going into your extruders are securely plugged in or visit makerbot.com/support/new/support to learn what your support options are.</p> <p>To clear Heating Errors 3 and 4, you will have to restart your MakerBot Replicator 2X.</p>
 <pre>Heating Failure #3 My extruders are losing temperature. Check my connections</pre>	
 <pre>Heating Failure #4 My temperature reads are failing. Check my connections</pre>	
 <pre>Heating Failure #5 I'm reading out of range temperatures. Check my connections</pre>	
 <pre>I can't read SD cards with storage larger than 2GB.</pre>	<p>Your MakerBot Replicator 2X cannot read SD cards larger than 2GB. Try a smaller card.</p>
 <pre>I saw a glitch in my SD card. If this is the first error try this build again.</pre>	<p>Your MakerBot Replicator 2X ran into a one-time problem while reading the SD card. The problem should not reoccur.</p>

LCD ERROR MESSAGES CONTINUED

Error Message	Description
	Something might be wrong with your extruder. Please visit makerbot.com/support/new/support to learn what your support options are.
	This is just an informational message. If you are loading or unloading filament, the process times out after five minutes.
	The onboard preheat sequence was interrupted by instructions sent by the software telling the MakerBot Replicator 2X to change the extruder temperature.
	These are the messages you could receive if your SD card is not formatted correctly or if there is something wrong with the card. Your MakerBot Replicator 2X can read SD cards: <ul style="list-style-type: none">· formatted for FAT16 SDSC card· no larger than 2GB.
	Make sure your SD card has not been removed from the MakerBot Replicator 2X during printing. If the card is still in its port on the MakerBot Replicator 2X, there might be a problem with the card itself. Make sure the card is formatted correctly.

MISALIGNED NOZZLES

MakerBot executes an alignment script on every MakerBot Replicator 2X before shipping. However, if plastic coming from the two extruders does not appear to be aligned correctly during dual extrusion prints, you can run the alignment script again at home.

1. Make sure filament is loaded into both extruders.
2. To start the nozzle alignment script, go to the LCD menu and navigate to **Utilities > Calibrate Nozzles**.
3. The MakerBot Replicator 2X will heat the build plate and extruders and then print a test print for aligning the nozzles.

First, one extruder prints a series of straight lines parallel to the front of the build platform, starting at the front left corner of the platform and extending to the back left corner of the platform. The other extruder then prints a second series of lines, perpendicular to the front of the build platform and starting at the center of the platform and extending to the left. The second extruder then prints a line alongside each line printed by the first extruder.

4. When the test print has completed, you will see two sets of lines. Each set includes two sets of 13 parallel lines, one set printed by each extruder.

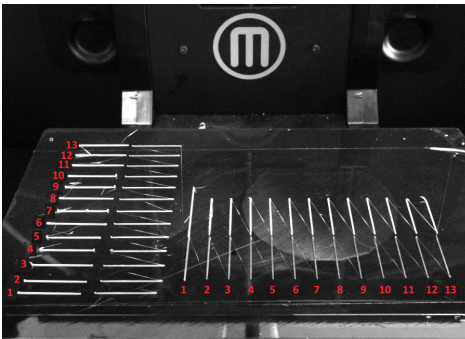

After the test print is completed, the LCD menu will provide new instructions and prompt you for input.

MISALIGNED NOZZLES CONTINUED

5. Look closely at your test print. First look at the set of lines to the left [the lines that are parallel to the front of the build plate]. Notice that the first lines on the left are farther from the front of the build plate than the first lines on the right. Examine the lines and find the pair of lines that match best. The best match will look the most like a single continuous line, with both test lines perfectly centered. Note the number. This is the best line for the Y axis.
6. Look at the set of lines to the right [the lines that are perpendicular to the front of the build plate]. Examine the lines and find the pair that match best. The best match will look the most like a single continuous line, with both test lines perfectly centered. Note the number. This is the best line for the X axis.
7. The LCD menu will prompt you to enter the line number that is best for the X axis and the line number that is best for the Y axis.
8. Use the arrow buttons to select a line number and the M button to select a line number. The MakerBot Replicator 2X will store this information about the locations of the extruder nozzles and use them to make future prints align better.

DOS AND DON'TS

MakerBot encourages you to tinker with your Replicator 2X Experimental 3D Printer, but there are some things we know are bad ideas, and you should know about them, too.

- Don't put any liquids into your extruder. Whether it's boiling water, acetone, or anything in between, it's not going to help and it could do a lot of harm.
- Don't overheat your extruder. We set temperature limits in our software for your safety and for the extruder's safety, so don't use anything other than the installed heaters to heat your extruder – don't use blowtorches, and don't detach parts of the extruder and put them in the oven.
- Don't use sharp tools to remove objects from the build plate – using a knife or a razor blade to remove prints is just as likely to hurt you as it is to help.
- Don't turn your MakerBot Replicator 2X off immediately after finishing a print. Give the extruder fans time to cool the extruder first.
- Don't drill out your extruder nozzle or drive any kind of metal tool through the nozzle. If you change the shape or size of your nozzle, the slicer will not be able to create accurate toolpaths.
- Don't try to replace your extruder nozzles. The nozzles are very securely attached to the extruder, and trying to remove them might result in the threaded portion of the nozzle shearing off and remaining inside the thermal core.
- Do make sure small and medium-sized prints work well before leaving your MakerBot Replicator 2X unattended for long prints.
- Do use only MakerBot Filament with your MakerBot Replicator 2X.
- Do be careful with the ceramic insulation on your extruders' thermal cores. Hitting them with tools or gripping them with pliers might break off parts of the ceramic insulation.

USEFUL TOOLS

Your MakerBot Replicator 2X package includes everything you need to start printing, but here are a few other things that might come in handy as you begin to experiment.

A Craft Spatula. A thin metal craft spatula is a great tool for removing stubborn prints from the build plate. Carefully work the edge of the spatula under the edge of your print, making sure to keep the spatula at a low angle. If the spatula is pointing down too steeply, it's more likely to damage your Kapton tape. When you've used the spatula to detach as much of the edges from the build surface as possible, twist the handle slightly. The print should pop right off.

Sandpaper and Files. Files are good for removing small imperfections in a print, or removing traces of support structures, and sandpaper is great at smoothing out layer lines. Use progressively finer grades of sandpaper for a smoother and smoother finish.

A Small Brush or Canned Air. You can use either of these tools to clean out the drive gears on your extruders. The drive gears are accessible through the outside sides of each extruder's drive block.

DIAGNOSING PRINT QUALITY ISSUES

Sometimes little things can go wrong with a print – things that are easy to fix, but only if you know what’s causing the problem. This guide can help: just find the picture of the problem you’re experiencing and read the tips on how to fix it.

Warping or Cracking

Are your prints curling off the build plate? This can happen during printing when the air around your print is too cool. Thermal expansion means that warmer layers closer to the extruder are shrinking, causing strain on the cooler layers below. The shrinking layers pull at the stable layers, warping the object. If the bond between two layers isn’t strong, the strain of the warping layers can actually cause cracks in the sides of your objects.



File Name: Frank's Head

Design by: michaelmelcone

Thingiverse: 142860

Warping occurs more often with ABS than with PLA because ABS expands more when it's heated. For either type of plastic, warping can be reduced by warming up the area around your object. When your print is surrounded by warm air, newly-printed layers will cool at a slower rate and adjacent layers will be closer in temperature. This is why the MakerBot Replicator 2X is fully enclosed. The enclosure keeps the heat from the extruders within the build area and keeps prints at a more constant temperature.

DIAGNOSING PRINT QUALITY ISSUES CONTINUED

FILAMENT VARIATION

Does it seem like there's too much or too little plastic being used in your prints? This can happen when your filament doesn't look or behave exactly how the slicing engine expects it to. Sometimes 1.75 mm plastic filament is actually closer to 1.65 mm or 1.85 mm. Your extruder can handle this range of sizes, but the slicer requires an accurate description of your filament to create a good toolpath.

To compensate for filament variation, you can create a custom profile. See **Using Custom Slicing Profiles** at www.makerbot.com/support/new/Desktop for instructions.

1. Unspool a couple of feet of filament and use a caliper to measure it at several different points. Average out those measurements and note the averaged value.
2. Create a custom profile and click the Edit Profile button to open the config file in a text editor. Then find the correct “feedDiameter” setting. You will see two “feedDiameter” settings, one enclosed in each of the extruder profiles. Change the first “feedDiameter” setting if you are printing using the right extruder on your MakerBot Replicator 2X and change the second “feedDiameter” setting if you are using the left extruder.
3. Save the config file and use your new custom profile to print.

If you are having trouble with the amount of plastic being extruded and the value entered for “feedDiameter” is accurate, look at the “feedstockMultiplier” setting. This setting compensates for any difference between the calculated volume of plastic going into the extruder and the actual amount of the plastic coming out of the extruder. Like the “feedDiameter” setting, the “feedstockMultiplier” setting appears twice in the config file – once in each of the two extruder profiles. When changing the “feedstockMultiplier” setting, make sure you choose the setting for the correct extruder.

DIAGNOSING PRINT QUALITY ISSUES CONTINUED

If you are overextruding, increase the “feedstockMultiplier” setting by 0.05, save the config file, and print again.

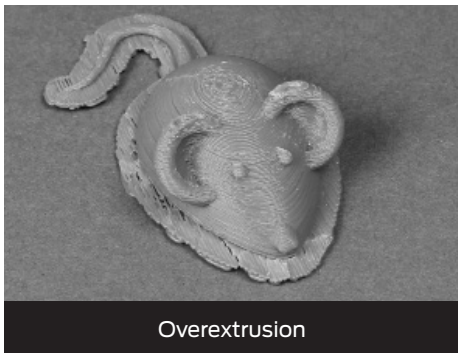

File Name: 3D mouse

Design by: DDStarkey

Thingiverse: 61909

If you are underextruding, decrease the “feedstockMultiplier” setting by 0.05, save the config file, and print your file again. Continue to decrease the value entered for this setting in increments.

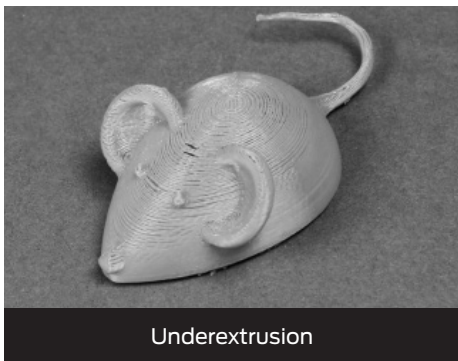

File Name: 3D mouse

Design by: DDStarkey

Thingiverse: 31909

DIAGNOSING PRINT QUALITY ISSUES CONTINUED

RIPPLING

Do you see faint vertical ripples on the walls of your prints? This is due to mechanical feedback and occurs at higher speeds. Reduce your print speed in the **Advanced Options** section of MakerBot Desktop's Settings dialog.

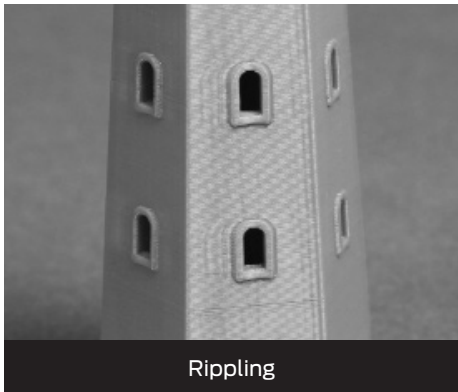

To print quickly but avoid rippling, reduce your print speed only on outer shells. To do this, you must create a custom profile. See **Using Custom Slicing Profiles** at makerbot.com/support/new/Desktop for instructions.

After you have created a custom profile, click the **Edit Profile** button to open the config file in a text editor. Find the “outlines” extrusion profile near the end of the config file. In this extrusion profile, find the “feedrate” setting. Enter a smaller number of millimeters per second, then save the config file and use your new custom profile to print.

AXIS DRIFT

Does it look like your whole print shifted sideways? This is the result of skipping on the X or Y-axis. This problem has multiple



possible causes.

Loose Belts: If the toothed belts that move the gantry are loose, the gear that drives them can start skipping over the teeth in the belt instead of grabbing onto them. See mbot.co/XjQREJ for a video on how to tighten the gantry belts.

Loose Drive Gear: If the drive gear in the extruder comes loose on the extruder motor shaft, the gear cannot grip the filament and drive it down into the extruder. Use the **Disassembling an Extruder** section on page 10 to remove the motor assembly from the extruder. Then:

1. Use the 2 mm hex wrench from the accessory box to remove the two bolts

DIAGNOSING PRINT QUALITY ISSUES CONTINUED

holding the drive block to the extruder motor. Remove the drive block and set it aside. Be careful with the drive block – if any of the pieces are detached, you might have a difficult time putting it back together.

2. Ensure that the drive gear is in the correct position on the motor shaft. The top of the drive gear should be about 2 mm from the end of the motor shaft. Locate the set screw that secures the gear to the motor shaft and make sure it touches the flat side of the motor shaft.
3. Use the 1.5 mm hex wrench from the accessory box to tighten the set screw against the motor shaft.
4. Return the drive block to the motor. Orient it so that the extruder lever arm points in the same direction as the white connector on the motor. Secure the drive block using the 2 mm hex wrench and the two bolts you removed earlier.
5. Return the extruder motor assembly to the extruder carriage.
6. Reconnect the motor wire harness to the top of the extruder motor.
7. As one piece, return the fan guard, the fan, the heat sink, and the spacers to the extruder. Use the 2.5 mm hex wrench to tighten the two bolts at the lower corners of the fan guard.



REFERENCE

SPECIFICATIONS

PRINTING

Print Technology:	Fused deposition modeling
Filament:	1.75 mm MakerBot ABS Filament 1.75 mm MakerBot Dissolvable Filament
Build Volume:	24.6 cm x 16.3 cm x 15.5 cm [9.7"W x 6.4"L x 6.1"H]
Layer Height Settings:	High 100 microns [0.0039 in] Medium 200 microns [0.0079 in] Low 300 microns [0.0118 in]
Positioning Precision:	XY: 11 microns [0.0004 in]; Z: 2.5 microns [0.0001 in]
Nozzle Diameter:	0.4 mm [0.015 in]

SOFTWARE

Software Bundle:	MakerBot MakerWare™
File Types:	STL, OBJ, Thing
Supports:	Windows [7+], Ubuntu [12.04+], Mac OS X [10.6+]

PHYSICAL DIMENSIONS

Without Spools:	49 x 32 x 38 cm [19.1 x 12.8 x 14.7 in]
With Spools:	49 x 42 x 38 cm [19.1 x 16.5 x 14.7 in]
Shipping Box:	57.5 x 49.5 x 40.6 cm [22.6 x 19.5 x 16 in]
Weight:	27.8 lbs [12.6 kg]
Shipping Weight:	39.25 lbs [17.8 kg]

TEMPERATURE

Ambient Operation:	15°–32° C [60°–90° F]
Storage Temperature:	0°–32° C [32°–90° F]

ELECTRICAL

AC Input:	100–240V, ~4 amps, 50–60 Hz
Power Requirements:	24V DC @ 9.2 amps
Connectivity:	SD card [FAT16, max 2 GB]

MECHANICAL

Chassis:	Powder-coated steel
Body:	PVC Panels
Build Platform:	356 aluminum
XYZ Bearings:	Wear-resistant, oil-infused bronze
Stepper Motors:	1.8° step angle with 1/16 micro-stepping.

GLOSSARY

ABS: Acrylonitrile butadiene styrene, a widely used thermoplastic, and the primary material used for making things on the MakerBot Replicator 2X.

BUILD PLATFORM: The support for the heated build plate. The build platform includes knobs for manual leveling.

DISSOLVABLE FILAMENT: A type of filament that will dissolve in a limonene bath. Ideal for the parts of a print that will be removed, such as rafts and support structures.

DRIVE GEAR: The gear that pushes the MakerBot Filament into the heated part of the extruder.

DUAL EXTRUSION: A process in which two extruders loaded with two different colors or kinds of plastic work together to 3D print an object.

ENCLOSURE LID: The clear acrylic hood that helps keep warm air inside the MakerBot Replicator 2X. The enclosure lid is shipped separately from the MakerBot Replicator 2X.

EXTRUDER: The assembly that draws the filament from the spool, melts it and pushes it through a nozzle onto the heated build plate. Your MakerBot Replicator 2X has two extruders.

EXTRUDER FANS: The fans that keep the MakerBot Replicator 2X extruder motors cool and disperse heat from the heat sinks.

FAN GUARDS: The grills that protect the extruder fans and protect the user from the fan blades.

FILAMENT GUIDE TUBES: The plastic tubes that guide the MakerBot Filament from the filament spools to the extruders.

GANTRY: The metal rods that allow the MakerBot Replicator 2X extruders to move on the X and Y axes.

GCODE: The computer language used to describe the toolpath your MakerBot Replicator 2X will use to 3D print an object. GCode is converted to X3G before being saved to your SD card or sent to your printer via USB.

HEAT SINKS: The components that dissipate heat from the cartridge heaters. They look like aluminum plates with fins.

HEATED BUILD PLATE: The heated surface on which the MakerBot Replicator 2X builds an object.

INFILL: The printed internal lattice that provides structural support for your object.

GLOSSARY CONTINUED

KAPTON TAPE: A heat-resistant film that adheres well to ABS plastic at high temperatures. Use it to cover the heated build plate so that objects will stick to the plate during the build.

LCD CONTROL PANEL: The liquid-crystal display at the front lower right corner of the MakerBot Replicator 2X. This control panel provides status information about the MakerBot Replicator 2X and includes control menus and diagnostics.

MAKERBOT FILAMENT: 1.75mm diameter plastic welding rod. This is the feedstock for your MakerBot Replicator 2X. MakerBot Filament comes in ABS, PLA, and Dissolvable plastics. The MakerBot Replicator 2X is optimized for ABS.

MAKERBOT DESKTOP: Free software created by MakerBot that allows you to explore Thingiverse, organize your files, prepare 3D models for printing, and buy premium models.

MANIFOLD: A term used to describe 3D models that consist of one completely enclosed three-dimensional shape with no holes, reversed faces, or extra geometry. Non-manifold models may cause problems for 3D printing and other applications.

MOTOR ASSEMBLY: The stepper motor and the drive block that push filament into the extruder. Each extruder contains a motor assembly.

MOTOR WIRES: The bundle of electrical wires that provides power to the motors.

NOZZLES: The openings at the end of the extruders from which melted plastic emerges to be spread onto the build plate.

PLA: Polylactic acid is a renewable bioplastic, and one of the materials from which MakerBot Filament is made.

POWER SUPPLY: The A/C power supply for the MakerBot Replicator 2X. It includes a block and two plugs.

SD CARD: Secure Digital memory card that can store digital data and be read by the MakerBot Replicator 2X. The SD card used with your MakerBot Replicator 2X must be formatted FAT 16 with a maximum capacity of 2 GB.

SHELLS: Printed outlines defining the shape of each layer of an object.

SPACERS: The plastic pieces that keep the extruder fans and heat sinks secure and in place.

SPOOL HOLDERS: The plastic pieces that attach to the back of the MakerBot Replicator 2X and hold the spools of Filament. The spool holder ensures that the MakerBot filament is fed evenly to the extruders.

STL: A widely used file format for 3D models.

GLOSSARY CONTINUED

.THING: A file format used by MakerBot Desktop that allows you to print multiple 3D models on the same build plate.

THINGIVERSE: A website for uploading and downloading 3D model files for use with the MakerBot Replicator 2X and other MakerBot 3D Printers.

THREADED ROD: The long metal rod behind the build platform that is threaded along its entire length. This rod allows the build platform to move up and down along the Z-axis.

TOOLPATH: The set of instructions your MakerBot Replicator 2X will use to build an object. Toolpaths for the MakerBot Replicator 2X must be saved as an X3G file.

USB CABLE: A cable that allows your computer to communicate with the MakerBot Replicator 2X.

.X3G: A compact format for describing the toolpath your MakerBot Replicator 2X will use to 3D print an object.

CONTACT US

SUPPORT

makerbot.com/support

Our website has extensive documentation and troubleshooting information about your MakerBot Replicator 2X. It's a great resource when you want to try to solve issues quickly on your own.

makerbot.com/support/select/

At MakerBot, we take pride in offering expert, responsive, friendly customer support to our customers around the world. If you need help resolving an issue with your MakerBot Replicator 2X, open a case with the MakerBot Support Team at the web address above.

SALES

sales@makerbot.com

To learn about other MakerBot products, including MakerBot Filament, please email the address above, or call our Sales Team at 1-347-334-6800.

FEEDBACK

thoughts@makerbot.com

For general questions, or to tell us what's on your mind, send an email to the address above. We love to hear from you, and using this email address helps keep our Sales and Support lines free for customers in need.



MakerBot®